

Front Setback: 15'
Rear Setback: 5'
Side Setback: 5'
Street Setback: 10'
Alley Setback: 10'

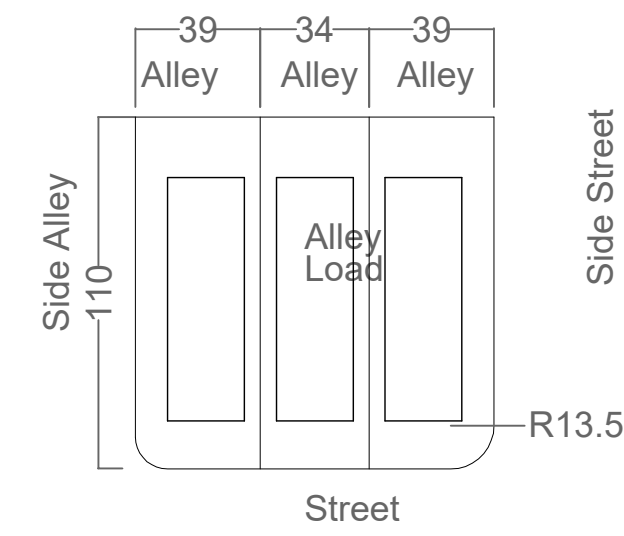

Front Setback: 15'
Rear Setback: 5'
Side Setback: 5'
Street Setback: 10'
Alley Setback: 10'

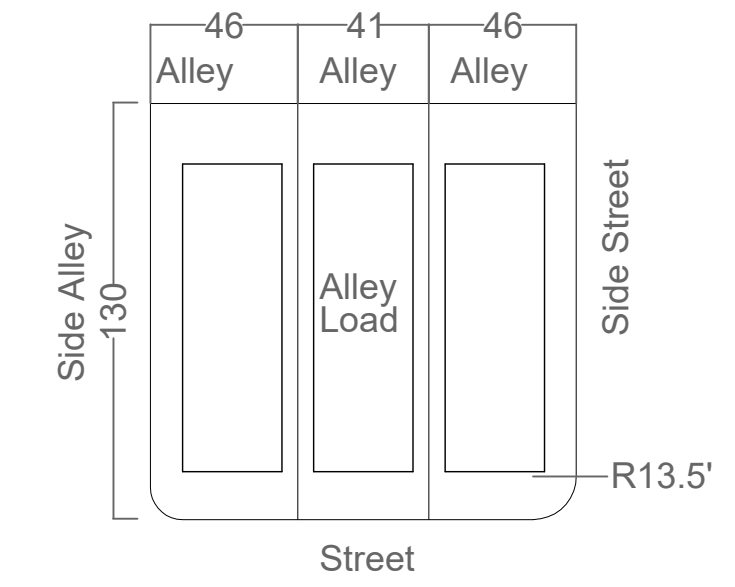

Front Setback: 15'
Rear Setback: 5'
Side Setback: 5'
Street Setback: 10'
Alley Setback: 10'

1
A1.0 **34' DETACHED**
PLAN & ELEVATION

N.T.S.

2
A1.0 **41' DETACHED**
PLAN & ELEVATION

N.T.S.

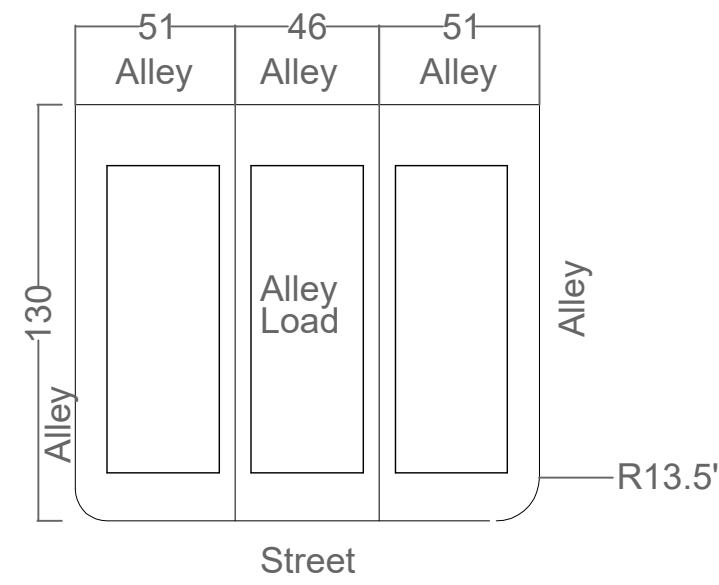

Front Setback: 15'
Rear Setback: 5'
Side Setback: 5'
Street Setback: 10'
Alley Setback: 10'

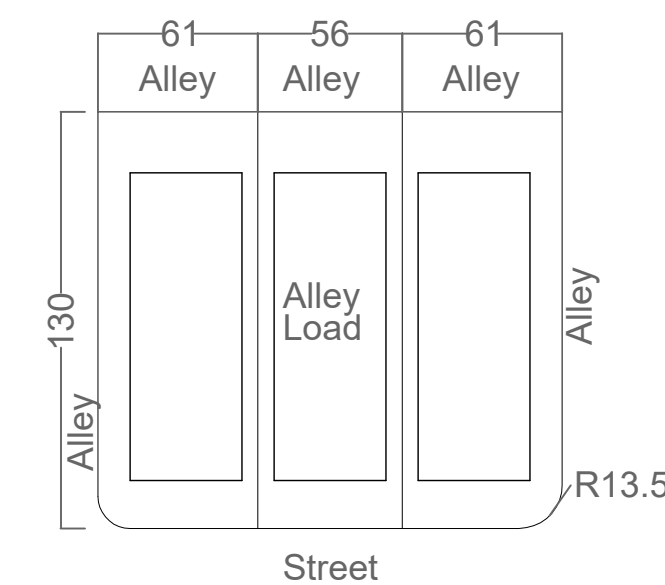

Front Setback: 15'
Rear Setback: 5'
Side Setback: 5'
Street Setback: 10'
Alley Setback: 10'

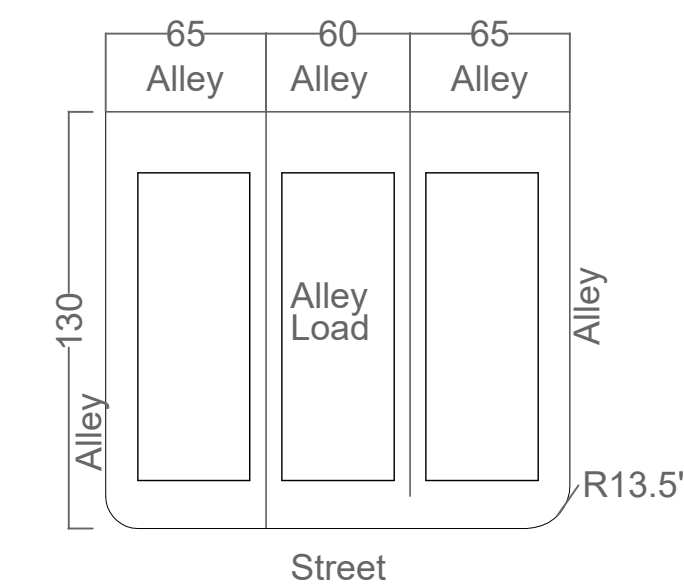

Front Setback: 15'
Rear Setback: 5'
Side Setback: 5'
Street Setback: 10'
Alley Setback: 10'

3
A1.0 **46' DETACHED**
PLAN & ELEVATION

N.T.S.

4
A1.0 **56' & 60' DETACHED**
PLAN & ELEVATION

N.T.S.

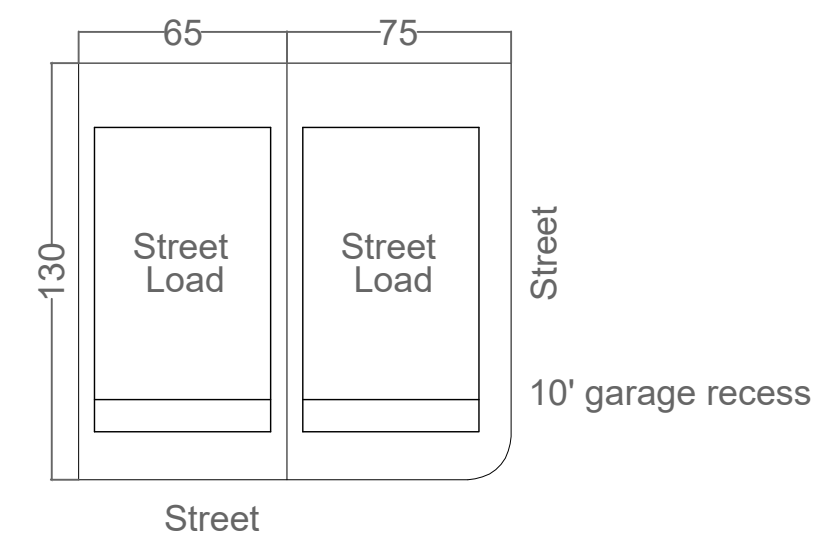

Front Setback: 15'
Rear Setback: 20'
Side Setback: 5'
Side Street Setback: 10'
Side Alley Setback: 10'

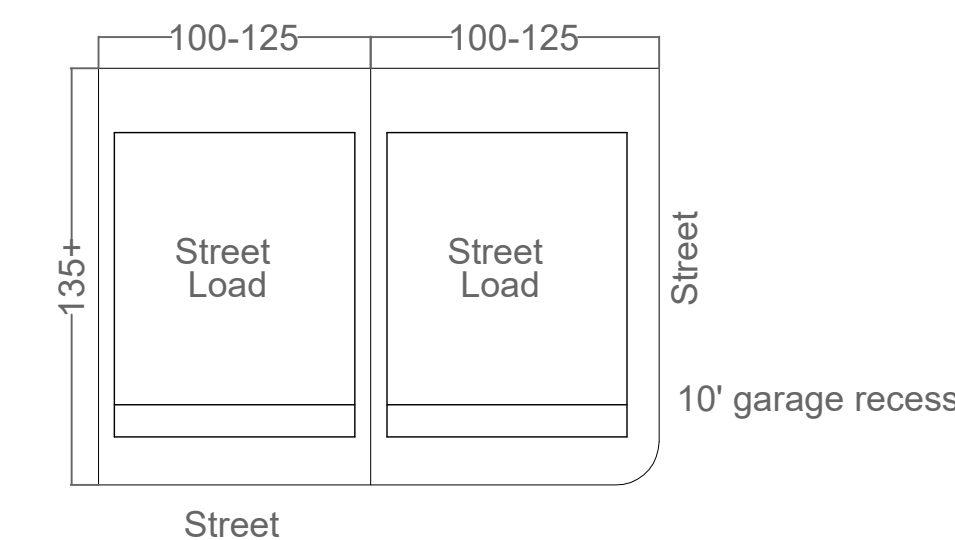

Front Setback: 15'
Rear Setback: 20'
Side Setback: 5'
Side Street Setback: 10'
Side Alley Setback: 10'

5
A1.0 **65' - 85' DETACHED**
PLAN & ELEVATION

N.T.S.

5
A1.0 **100'-125' DETACHED**
PLAN & ELEVATION

N.T.S.

The home elevations shown here are representative of the homes planned for Southbrooke. They are the basis for design review by the City of Franklin at the time of Site Plan Submittal. Based on my professional experience, the plans presented meet or exceed the design standards set forth by the City of Franklin.

Greg Gamble, Registered
Landscape Architect.



Revision Date

△	_____
△	_____
△	_____
△	_____

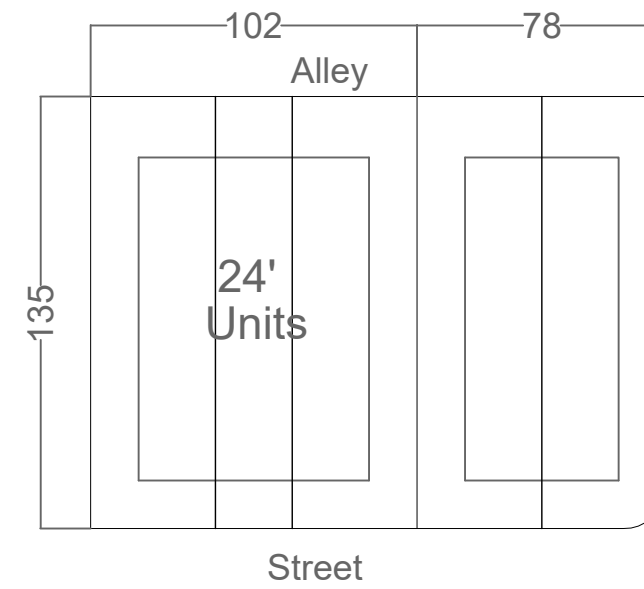

Front Setback: 15'
 Rear Setback: 5' (18' for Parking)
 Side Setback: 15'
 Street Setback: 15'
 Alley Setback: 10'



3 UNIT



2 UNIT

1
 24' ATTACHED
 PLAN & ELEVATION

N.T.S.



GARAGE BELOW STREET



GARAGE ABOVE STREET

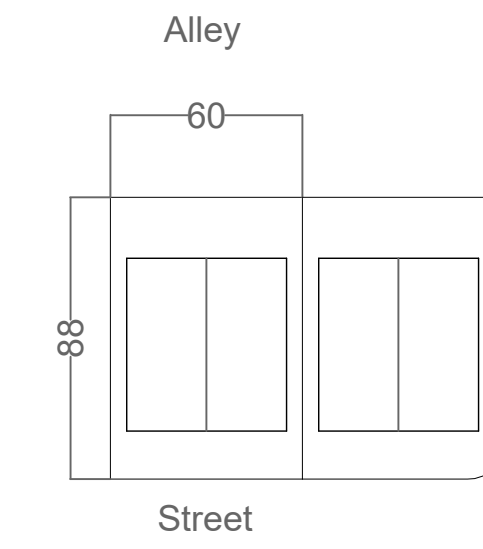

Front Setback: 15'
 Rear Setback: 18'
 Side Setback: 5'
 Street Setback: 10'
 Alley Setback: 10'

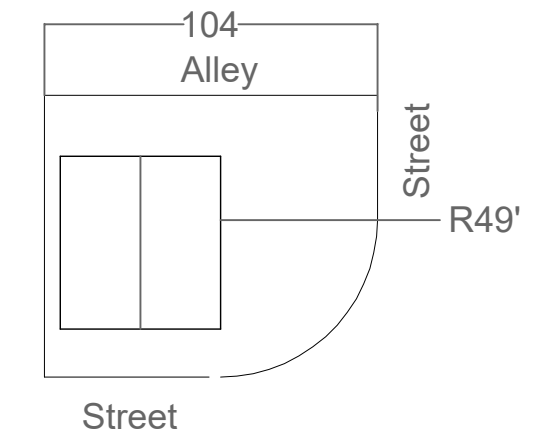

The 49' radius only applies where the street makes a 90 degree turn with no intersecting street.

2
 60' ATTACHED
 PLAN & ELEVATION

N.T.S.

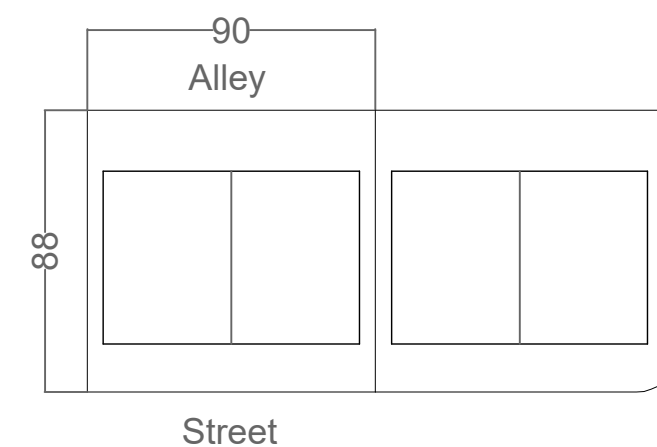

Front Setback: 15'
 Rear Setback: 18'
 Side Setback: 5'
 Street Setback: 10'

3
 90' ATTACHED
 PLAN & ELEVATION

N.T.S.

The home elevations shown here are representative of the homes planned for Southbrooke. They are the basis for design review by the City of Franklin at the time of Site Plan Submittal. Based on my professional experience, the plans presented meet or exceed the design standards set forth by the City of Franklin.

Greg Gamble, Registered Landscape Architect.



Revision	Date
△	_____
△	_____
△	_____
△	_____