

# CITY OF FRANKLIN, TENNESSEE PROCUREMENT AGREEMENT

(City of Franklin Contract No. 2014-0346)

THIS PROCUREMENT AGREEMENT ("AGREEMENT") is by and between the City of Franklin, Tennessee ("CITY"), and North America Fire Equipment Co., Inc., also known as NAFECO, ("VENDOR"), who mutually agree as follows:

1. CITY issued on November 21, 2014 Purchasing Office Solicitation No. 2015-017, a procurement solicitation for bids for supply and delivery of firefighting nozzles and hydrant wyes ("SOLICITATION"), a copy of which is attached hereto as Attachment No. 1 and hereby incorporated by reference as if fully set forth herein.
2. In response to CITY's SOLICITATION, VENDOR submitted a bid dated December 2, 2014 ("SUBMITTAL"), a copy of which is attached hereto as Attachment No. 2 and hereby incorporated by reference as if fully set forth herein.
3. CITY awarded on January 27, 2015 and now desires to place an order from VENDOR for supply and delivery of firefighting nozzles and hydrant wyes pursuant to SOLICITATION and SUBMITTAL. The total value of the award is \$56,614.34.
4. In the event of a conflict between CITY's SOLICITATION and VENDOR's SUBMITTAL, CITY's SOLICITATION shall supersede any conflicting terms and conditions within VENDOR's SUBMITTAL, except for any exceptions identified by VENDOR in its SUBMITTAL and accepted at the time of award by CITY.

EXECUTED THIS \_\_\_\_\_ DAY OF \_\_\_\_\_ 20\_\_.

For VENDOR: NAFECO

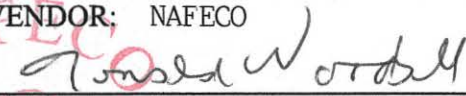
  
(signature of VENDOR's authorized representative)

TITLE: VICE PRESIDENT

For CITY:

\_\_\_\_\_  
(signature of CITY's authorized representative)

TITLE: Mayor

Approved as to Form:

\_\_\_\_\_  
Attorney for City of Franklin

**CITY OF FRANKLIN, TENNESSEE**  
**PROCUREMENT AGREEMENT**  
(City of Franklin Contract No. 2014-0346)

---

**Attachment No. 1**

**SOLICITATION**

## NOTICE TO BIDDERS

**NOTICE IS HEREBY GIVEN** that the City of Franklin, TN, will receive sealed written bids in the City's Purchasing Office, City Hall, Suite 107, 109 3<sup>rd</sup> Avenue South, Franklin, TN 37064, until 2:00 p.m. Central Time on December 4, 2014, at which time and location they will be publicly opened, for the following procurement: supply and delivery of firefighting nozzles and hydrant wyes (Purchasing Office Solicitation No. 2015-017). Bids must be prepared and submitted in accordance with the City of Franklin's specifications and other procurement documents pertaining to this solicitation, including any addenda that may be issued, available on the Business Opportunities page of the City's website (<http://www.franklinton.gov/>) or by contacting the City of Franklin Purchasing Office ([purchasing@franklinton.gov](mailto:purchasing@franklinton.gov); 615/550-6692). The City reserves the right to reject any and all bids, and to waive formalities.

---

{text below this line not to be published}

DATE OF PUBLICATION OF THIS NOTICE TO BIDDERS: **November 20, 2014**

# City of Franklin Instructions for Bidders

Purchasing Office Solicitation No.: 2015-017

---

1. Solicitation identified: These instructions apply to the following procurement:  
**supply and delivery of firefighting nozzles and hydrant wyes**  
**Purchasing Office Solicitation No.: 2015-017**
2. Solicitation packet component documents: These Instructions for Bidders accompany the following documents which, in total, represent the complete solicitation packet:
  - a. Notice to Bidders;
  - b. City of Franklin Instructions for Bidders (this document);
  - c. City of Franklin specifications;
  - d. City of Franklin Bid Submittal Form;
  - e. City of Franklin Affidavit of Non-Collusion;
  - f. City of Franklin Standard Procurement Terms and Conditions; and
  - g. City of Franklin Procurement Agreement form.
3. Location of bid opening: Bid opening will be held in the City of Franklin Purchasing Office (see address below, under “Delivery of bids”), or at another location within the City of Franklin City Hall. If the location of the bid opening is other than at the Purchasing Office, such location shall be posted on the front door of the Purchasing Office at least five (5) minutes before the appointed time of bid opening.
4. Who may attend bid openings: City of Franklin bid openings are open to the public. Bidders are specifically welcome to attend.
5. Withdrawal of bids; expiration of submittal validity (see also “Errors and omissions” below):
  - a. Before the bid submittal deadline, submitted bids may be withdrawn upon the request of the submitting party. At the request of the submitting party, withdrawn bids may be returned unopened to the submitting party but only at the submitting party’s expense. Such a request to withdraw a bid and such a request to return a withdrawn bid must be in writing, shall be addressed to the Purchasing Office, must be received by the Purchasing Office before the bid submittal deadline, and may be submitted via either e-mail ([purchasing@franklintn.gov](mailto:purchasing@franklintn.gov)) or fax (615/550-0079).
  - b. After the bid submittal deadline, submitted bids may not be withdrawn.
  - c. Before award, all bids and associated pricing as submitted shall be considered valid and may be accepted by the City at least through **February 28, 2015** and until the date indicated on the bidder’s Bid Submittal Form as the “last date that bid and associated pricing is valid and may be accepted by the City,” up to when the specified item is no longer available for purchase new.
  - d. After award, the accepted bid and associated pricing shall be considered valid until the specified item has been supplied and delivered to the satisfaction of the City of Franklin. However, quoted bid prices are to be offered by the bidder on a per unit basis for potential future orders at least through **July 31, 2015** and until the date indicated on the bidder’s Bid Submittal Form as the “last date that bid pricing on a per unit basis is valid for potential future orders,” up to when the specified item is no longer available for purchase new.

# City of Franklin Instructions for Bidders

Purchasing Office Solicitation No.: 2015-017

---

6. Submittal timing: Bids are to be delivered *no earlier than* five (5) City of Franklin business days before the submittal deadline. Bids delivered either more than five (5) City of Franklin business days before the submittal deadline or at any time after the submittal deadline shall be rejected and not evaluated.
7. Submittals rejected on account of timing: Submitters of bids rejected on account of timing shall be notified by the City of such rejection as soon as practicable. Bids rejected on account of timing may be retrieved by the submitter at the submitter's expense. The City shall promptly cause to be destroyed and discarded any and all bids rejected on account of timing and not retrieved by the submitter within five (5) City of Franklin business days of the submitter being notified of the rejection.
8. Bid to be sealed: Each bid shall be submitted inside one (1) or more sealed container(s).
9. Submittal to include one (1) set of original documents plus two (2) complete duplicate sets: Please submit one (1) set of bid documents with original signatures plus two (2) complete duplicate sets.
10. Bid submittal contents: Included with the bid are to be the following:
  - a. City of Franklin Bid Submittal Form, executed in full;
  - b. Detailed vendor-supplied description of bid product(s) or item(s);
  - c. Detailed vendor-supplied description of the warranties included in the pricing;
  - d. City of Franklin specifications for this procurement, marked by the bidder as to compliance therewith as per the instructions therein;
  - e. Detailed vendor-supplied identification, listing and description of any exceptions to the written specifications as per the instructions therefor;
  - f. Vendor-supplied contact information for a minimum of three references (see below);
  - g. City of Franklin Standard Procurement Terms and Conditions, with the vendor's contact information inserted;
  - h. Vendor's proposed terms and conditions, if any, that are not inconsistent with the City's Standard Procurement Terms and Conditions; and
  - i. City of Franklin Affidavit of Non-Collusion, executed in full.
11. Bid container label: The outside face of the bid container(s) must be labeled with the following information:
  - a. the bidder's name and address; and
  - b. the following text:

SEALED BID

**City of Franklin solicitation no. 2015-017 (firefighting nozzles and hydrant wyes)**

**NOT TO BE OPENED EXCEPT AT  
BID OPENING December 4, 2014,  
2:00 p.m. Central Time**

# City of Franklin Instructions for Bidders

Purchasing Office Solicitation No.: 2015-017

---

12. Delivery of bids:
  - a. Bids are to be addressed and delivered to:

City of Franklin Purchasing Office  
Franklin City Hall, Suite 107  
109 3<sup>rd</sup> Ave. South  
Franklin, TN 37064
  - b. Bids must be printed on paper and signed. A bid may be mailed via U.S. Mail or shipped or hand-delivered via courier. Bids submitted to the City electronically (e.g., via e-mail or fax) are not permitted and shall be rejected.
  - c. A bid is not considered delivered unless and until it has been received by the City of Franklin Purchasing Office at the physical location listed above. A bid that is en route via U.S. Mail or courier, or delivery of a bid to another City office or location, does not in and of itself constitute delivery of that bid to the City of Franklin Purchasing Office.
  - d. The Purchasing Office shall exclusively determine whether a bid was received before the submittal deadline, and shall use the most accurate time piece available in its office as an aide to doing so.
13. Reference request: Bidders must provide three references for similar goods or products sold within the last twelve months. Information to be provided shall include: client name, client address, description of good or product sold, contact name and title, and contact telephone number.
14. Selection criteria: Selection of the lowest and best responsive and responsible bid shall be based upon a combination of some or all of the following factors: the quoted purchase costs and/or life-cycle costs to the City of bids that are responsive to the solicitation; compliance with the City's instructions, specifications and standard procurement terms and conditions; any terms and conditions stated by the bidder in the bid; anticipated timeliness of delivery of the bid item(s); the character, integrity and reputation of the bidder; the results of any reference checks; and any prior experience of the City of Franklin with the bidder and/or the bid item(s) and/or any component thereof.
15. Bid tabulation; notice of intent to award: The tabulation of bids received, as prepared by the City, may also indicate a recommendation as to the selection of the lowest and best responsive and responsible bid, in which case the tabulation of bids received also functions as the City's notice of intent to award. Bidders may request a copy of the tabulation of bids received by contacting the City's Purchasing Office (see contact information below) at any time on or after the tentative date of release of the City's tabulation of bids received and notice of intent to award (see Specifications).
16. Awards to be made by BOMA: Purchases shall be awarded by the City of Franklin's Board of Mayor and Aldermen. See Specifications for tentative date of award. Purchases shall be awarded to the bidder who submits the lowest and best responsive and responsible bid.

# City of Franklin Instructions for Bidders

Purchasing Office Solicitation No.: 2015-017

---

17. Other documents to be required of successful bidder: Before award of the procurement by the City, the successful bidder (that is, the vendor who is recommended be awarded the purchase) shall provide the following documents:
  - a. Vendor-supplied agreement or contract, if any, by and between the City and the bidder to be awarded the procurement, the final terms and conditions of which are mutually acceptable to both parties, executed for the vendor;
  - b. City of Franklin Procurement Agreement, executed for the vendor; and
  - c. If the vendor prefers to be paid by direct deposit (such as “ACH” or “Electronic Funds Transfer”) as opposed to credit card, and if the vendor has not been paid by the City by means of direct deposit within the last two (2) years, then the vendor shall submit a completed City of Franklin Vendor Information Form and IRS Form W-9 (both of which forms are available upon request from the Purchasing Office).
  
18. City’s right to reject bids, waive formalities: The City of Franklin reserves the right to reject any and all bids, and to waive formalities.
  
19. Errors and omissions (see also “Withdrawal of bids; expiration of submittal validity” above):
  - a. Errors made by the bidder on the Bid Submittal Form or elsewhere in the bidder’s submittal packet that are discovered by the bidder before submittal shall be corrected by the bidder. If such a correction results in altering but not replacing one or more documents, then the bidder’s representative shall initial each such correction in non-erasable ink.
  - b. Errors made by the bidder on the Bid Submittal Form or elsewhere in the bidder’s submittal packet that are discovered by the bidder after submittal but before the bid submittal deadline may be corrected by the bidder but only by submitting such replacement documents as necessary to make the correction. Such a submittal of replacement documents shall be labeled “SEALED AMENDED BID” and shall otherwise be submitted pursuant to the same instructions above as for the submittal of the original bid documents. Such a submittal of replacement documents shall not be submitted electronically, and shall not be submitted after the bid submittal deadline.
  - c. Uncorrected errors made by the bidder on the Bid Submittal Form or elsewhere in the bidder’s submittal packet shall be considered on a case-by-case basis by the City. Uncorrected errors made by the bidder may be deemed by the City to be so severe as to make the bid non-responsive. At the discretion of the City, bidders may be permitted to clarify a submitted bid, but no bid shall be altered or amended by the bidder after submittal. In the case of a discrepancy between the bidder’s unit price for a particular line item as quoted in the bid and the unit price calculated by dividing the bidder’s extension price for that same line item by the quantity indicated for that same line item, then the bidder’s unit price for that line item as quoted in the bid shall prevail.
  - d. Omissions from a bidder’s submittal packet shall be considered on a case-by-case basis by the City. Omissions may be deemed by the City to be so severe as to make the bid non-responsive. At the discretion of the City, bidders may be permitted to clarify a submitted bid, but no bid shall be altered or amended by the bidder after submittal.

# City of Franklin Instructions for Bidders

Purchasing Office Solicitation No.: 2015-017

---

20. Questions, requests for clarifications, and requests to revise the procurement solicitation; addenda: To ask questions, to request clarifications about any aspect of this procurement solicitation, or to request revisions to the procurement solicitation before the deadline for optional submittal in writing of questions seeking to revise or clarify any aspect of the procurement solicitation, please contact:

City of Franklin Purchasing Office (see address above)  
[purchasing@franklintn.gov](mailto:purchasing@franklintn.gov)  
Tel: 615/550-6692  
Fax: 615/550-0079

Depending upon the inquiry, the City may request that the question, request for clarification, or request for revision be submitted in writing, whereupon the City may make all vendors known or thought to be interested in the solicitation aware of the inquiry and of the City's response thereto.

Addenda to this procurement solicitation may be issued. Before submitting its response, it is the responsibility of each respondent to confirm whether any addenda to this procurement solicitation have in fact been issued by the City. To do so, please contact the City's Purchasing Office (see contact information above).

21. Communication with City during procurement phase: Any questions about either the content of or the procurement process pertaining to this procurement solicitation should be addressed as described above. Until the procurement award has been made, vendors shall not communicate about either the content of or the procurement process pertaining to this procurement solicitation with any official, employee or other representative of the City except through the City's Purchasing Office. The City reserves the right to disqualify any vendor that initiates unauthorized communication with the City during the procurement phase.
22. Vendor protest: A vendor who feels the need to object to either a deficiency of this procurement solicitation or a proposed award pertaining to this procurement solicitation are encouraged, as soon as possible, to express their concerns to and seek remedy from the Purchasing Manager (see contact information above). Vendors who are not satisfied with, or who choose not to pursue, such an informal resolution of their concerns and who feel compelled to lodge a formal protest about some aspect of a City procurement not pertaining to new construction shall do so pursuant to the City's Vendor Protest Procedure for City procurements not pertaining to new construction, a mandatory administrative procedure which all aggrieved actual or prospective vendors must utilize and exhaust prior to seeking judicial review or remedy. For a copy of the City's Vendor Protest Procedure for City of Franklin procurements not pertaining to new construction, please contact the City's Purchasing Office (see contact information above) or click on the following link: <http://www.franklintn.gov/government/finance-administration/purchasing-office/vendor-protest-procedure>.



# City of Franklin Specifications

Purchasing Office Solicitation No.: 2015-017

---

1. Solicitation identified: These specifications apply to the following procurement:  
**supply and delivery of firefighting nozzles and hydrant wyes**  
**Purchasing Office Solicitation No.: 2015-017**
2. Notice to Bidders publication date: **November 20, 2014**
3. Solicitation release date: **November 21, 2014**
4. Deadline for optional submittal in writing of questions seeking to revise or clarify any aspect of this procurement solicitation: **November 25, 2014, 2:00 p.m. Central Time**
5. Bids submittal deadline and scheduled opening: **December 4, 2014, 2:00 p.m. Central Time**
6. Tentative date of release of City's tabulation of bids received and notice of intent to award: **January 9, 2015**
7. Tentative date of award: Meeting of Board of Mayor and Aldermen at which is tentatively scheduled to be awarded the selection of the lowest and best responsive and responsible bid: **January 27, 2015**
8. Objective: To secure, by means of a competitive procurement process, the selection of the lowest and best responsive and responsible bid from a vendor to furnish all materials and means necessary to supply and deliver to the City of Franklin Fire Department firefighting nozzles and hydrant wyes as specified below. See the accompanying Instructions for Bidders for additional information and instructions.
9. Exceptions:
  - a. In order to avoid the need to take an exception to a specification, potential bidders may request revisions to the specifications before the deadline for optional submittal in writing of questions seeking to revise or clarify any aspect of the specifications. See the accompanying Instructions for Bidders for contact information.
  - b. Any deviation or variance from the City's specifications shall be considered to be an exception.
  - c. Any exceptions to the City's specifications shall be identified by the bidder on the City's specifications document as well as listed and described in detail, along with any other exceptions to this procurement solicitation, in a separate written document to be prepared and submitted by the bidder, referencing any subsection number. Such listing

# City of Franklin Specifications

## Purchasing Office Solicitation No.: 2015-017

---

shall include a description of exactly how such exceptions deviate from the City's expectations as expressed and implied by the procurement solicitation, and shall indicate why such exceptions should be judged by the City to meet or exceed those expectations. Any and all exceptions to this procurement solicitation which the City, in its sole discretion, deems not to meet or exceed the City's intention as expressed and implied by the procurement solicitation may be considered by the City as a factor in evaluating the bid.

10. General terms and conditions:

- a. Bid price: The bid price shall include all equipment, labor, materials, permit(s), freight and required insurance to supply and deliver the specified products.
- b. Delivery terms: As a matter of practice, the City of Franklin expects vendor to ship any and all deliverables FOB destination, freight prepaid and added. The City's preferred delivery terms, as described in the preceding sentence, are offered to the bidder or proposer as a condition of award. If the City's preferred delivery terms are unacceptable to the bidder or proposer, then the bidder or proposer shall indicate on the Submittal Form its preferred delivery terms. Delivery terms may be a factor in the City's selection criteria. Delivery terms are non-negotiable after award is made.
- c. Payment terms: As a matter of practice, the City of Franklin pays for goods and/or services only after receipt and acceptance by the City of such goods and/or services, and only after receipt of an accurate, proper, complete and itemized invoice for such goods and/or services, net 30 calendar days from date of delivery and/or completion/installation/rendering or date of invoice, whichever is later. The City's preferred payment terms, as described in the preceding sentence, are offered to the bidder or proposer as a condition of award. If the City's preferred payment terms are unacceptable to the bidder or proposer, then the bidder or proposer shall indicate on the Submittal Form its preferred payment terms. Payment terms may be a factor in the City's selection criteria. Payment terms are non-negotiable after award is made.
- d. Applicable laws and regulations: All applicable federal and state laws, city ordinances, orders, rules and regulations of all authorities having jurisdiction over the specified products shall apply to the quoted purchase price, and they will be deemed to be included in these specifications the same as though they are written out in full herein.
- e. Standard Procurement Terms and Conditions: By submitting its bid, the vendor certifies that it has read and accepts all terms, conditions and requirements of this solicitation, including the terms and conditions identified and listed in the City of Franklin Standard Procurement Terms and Conditions attached hereto and hereby incorporated by reference.
- f. Refusal to honor submittal: If and after an award is made by the City, if the vendor refuses to execute an agreement or contract or in any other way honor the terms and conditions of its submittal, the City shall be entitled to seek compensation for its damages, which may include the cost of conducting a new solicitation.

# City of Franklin Specifications

## Purchasing Office Solicitation No.: 2015-017

---

g. Confidential and/or proprietary information; trade secrets. All contents of all submittals are subject to public disclosure and shall not contain any confidential and/or proprietary information and/or trade secrets. Further, by submitting its bid, the vendor indemnifies and holds the City of Franklin harmless against any loss or damage, including reasonable attorney fees, it may incur as a result of the City's reliance upon the vendor's representation that materials supplied by the vendor do not contain trade secrets or proprietary information which is not subject to public disclosure.

11. Detailed specifications: Please note:

- Bidders are required to submit with their bid a detailed description of all bid products and/or items.
- Bidders are required to mark with a "C" the blank line next to any specification below to which their bid COMPLIES.
- Bidders are required to mark with an "E" the blank line next to any specification below to which their bid takes EXCEPTION.
- Any exceptions to the City's specifications shall be identified by the bidder on the City's specifications document as well as listed and described in detail, along with any other exceptions to this procurement solicitation, in a separate written document to be prepared and submitted by the bidder, referencing any subsection number. Such listing shall include a description of exactly how such exceptions deviate from the City's expectations as expressed and implied by the procurement solicitation, and shall indicate why such exceptions should be judged by the City to meet or exceed those expectations.
- Bidders are required to submit with their bid these Specifications for this procurement, marked by the bidder as to compliance herewith as per the instructions above.

**11.1. General.**

- 11.1.1.** \_\_\_\_\_ City intends for the Franklin Fire Department to use the specified nozzles and wyes on firefighting hand lines in the activity of fire suppression. Items as bid shall be designed and manufactured according to industry standards for this intended use.
- 11.1.2.** \_\_\_\_\_ Nozzles and wyes are to be purchased new and unused by the City.
- 11.1.3.** \_\_\_\_\_ Purchased nozzles and wyes shall be of current production only.
- 11.1.4.** \_\_\_\_\_ The quantities of items to be ordered upon award of the bid are noted below. However, quoted bid prices are to be offered by the bidder on a per unit basis for potential future orders at least through July 31, 2015 and until the date indicated on the bidder's Bid Submittal Form as the "last date that bid price on a per unit basis is valid for potential future orders," up to when the specified item is no longer available for purchase new.

# City of Franklin Specifications

Purchasing Office Solicitation No.: 2015-017

---

- 11.2. Warranty.**
- 11.2.1.** \_\_\_\_\_ Manufacturer’s warranty, for durations not less than the durations indicated below, shall be included in the bid.
- 11.2.2.** \_\_\_\_\_ Bidder shall indicate the durations of the manufacturer’s warranty on the Bid Submittal Form.
- 11.2.3.** \_\_\_\_\_ Bidder shall supply a description of the manufacturer’s warranty along with the Bid Submittal Form.
- 11.3. Delivery, Documentation and Training.**
- 11.3.1.** \_\_\_\_\_ Vendor shall indicate on the Bid Submittal Form the estimated time of delivery, measured in number of calendar days after receipt of order.
- 11.3.2.** \_\_\_\_\_ Vendor specifically acknowledges and accepts City’s standard delivery terms as expressed under “General terms and conditions” above.
- 11.3.3.** \_\_\_\_\_ Vendor shall include delivery and unloading or offloading and deposit of the nozzles and wyes at the following location:
- City of Franklin Fire Department Headquarters  
Franklin City Hall  
109 3<sup>rd</sup> Ave. South  
Franklin, TN 37064
- 11.3.4.** \_\_\_\_\_ Vendor shall provide any labor and equipment necessary to unload or offload the deliverable in a manner (a) consistent with best practices for shipping and receiving, (b) that does not involve undue risk to the safety of anyone at the delivery site or the condition of the deliverable, (c) that does not involve City personnel, and (d) without the need for a loading dock.
- 11.3.5.** \_\_\_\_\_ Delivery shall be made between the hours of 7:00 a.m. and 3:30 p.m., Monday through Friday except holidays observed by the City.
- 11.3.6.** \_\_\_\_\_ Documentation, including both operator and service manuals, warranties, detailed troubleshooting information, and any available unit-specific training videos, shall be provided upon delivery of unit.
- 11.3.7.** \_\_\_\_\_ Training by a qualified product manufacturer representative shall be provided within 30 days of delivery of the nozzles and wyes.
- 11.3.8.** \_\_\_\_\_ Training shall be delivered in a minimum of three (3) three-hour sessions on three (3) separate days to be scheduled on days mutually acceptable to the City and the manufacturer’s representative.

# City of Franklin Specifications

Purchasing Office Solicitation No.: 2015-017

---

- 11.3.9. \_\_\_\_\_ Training shall include both detailed instruction and hands-on demonstrations of the nozzles utilizing a flow meter and piezometer for pumping and handling operation, routine maintenance and routine repair.
- 11.4. **Hardware.**
- 11.4.1. \_\_\_\_\_ All nozzle tip pieces utilizing a polymer bumper, all polymer bales and all polymer pistol grips shall be available in a variety of colors. Color options will be made available in any variety and combination of the COF Fire Department's choosing.
- 11.4.2. \_\_\_\_\_ All fog tips shall use an interchangeable baffle to control flow.
- 11.4.3. \_\_\_\_\_ All valves shall be of full round ball construction.
- 11.4.4. \_\_\_\_\_ All threads shall be NST.
- 11.4.5. \_\_\_\_\_ All nozzle tips and bases shall be laser etched for internal inventory purposes. Franklin Fire Department will provide to the awarded vendor an inventory number for each piece, maximum 5 characters long.
- 11.4.6. \_\_\_\_\_ All nozzles shall be maintainable by routine maintenance only. Routine maintenance defined as cleaning, not involving disassembling the nozzle, other than break-apart pieces, or any pieces of it. No lubrication shall be required to maintain any part of the nozzle base or tip.
- 11.4.7. \_\_\_\_\_ Akron Brass 1-1/2" break-apart nozzles, consisting of a Style 2431 shutoff and a Style 4866 fog tip, for each nozzle.
- 11.4.7.1. \_\_\_\_\_ A quantity of forty-six (46).
- 11.4.7.2. \_\_\_\_\_ The Style 2431 Saber Shutoff shall have a 1-1/2" inlet and 1-1/2" outlet, be made of Pyrolite, have pistol grip and integrated 15/16" smoothbore, and shall include a manufacturer's warranty for a minimum duration of five (5) years.
- 11.4.7.3. \_\_\_\_\_ The Style 4866 Assault fixed orifice fog tip shall be calibrated to 175 GPM at 50 PSI, have a 1-1/2" swivel inlet, be made of Pyrolite, and shall include a manufacturer's warranty for a minimum duration of ten (10) years.
- 11.4.7.4. \_\_\_\_\_ The fog nozzle shall be equipped with spinning teeth, ¼ turn quick change adjustment from straight stream to fog pattern and raised lug to indicate fog pattern location.

# City of Franklin Specifications

Purchasing Office Solicitation No.: 2015-017

---

- 11.4.8.** \_\_\_\_\_ Akron Brass 2-1/2” break-apart nozzles, consisting of a Style 2433 shutoff and a Style 4824 fog tip, for each nozzle.
- 11.4.8.1.** \_\_\_\_\_ A quantity of twelve (12).
- 11.4.8.2.** \_\_\_\_\_ The Style 2433 Saber Shutoff shall have a 2-1/2” inlet and 1-1/2” outlet, be made of Pyrolite, have pistol grip and integrated 1-1/4” smoothbore, and shall include a manufacturer’s warranty for a minimum duration of five (5) years.
- 11.4.8.3.** \_\_\_\_\_ The Style 4824 High-Range Assault fixed orifice fog tip shall be calibrated to 250 GPM at 50 PSI, have a 1-1/2” swivel inlet, be made of Pyrolite, and shall include a manufacturer’s warranty for a minimum duration of ten (10) years.
- 11.4.8.4.** \_\_\_\_\_ The fog nozzle shall be equipped with spinning teeth, 1/4 turn quick change adjustment from straight stream to fog pattern and raised lug to indicate fog pattern location.
- 11.4.9.** \_\_\_\_\_ Akron Brass 2-1/2” break-apart nozzles, consisting of a Style 2433 shutoff and a Style 1417 plain tip, for each nozzle.
- 11.4.9.1.** \_\_\_\_\_ A quantity of fourteen (14).
- 11.4.9.2.** \_\_\_\_\_ Shall include a manufacturer’s warranty for a minimum duration of five (5) years.
- 11.4.9.3.** \_\_\_\_\_ The Style 2433 Saber Shutoff shall have a 2-1/2” inlet and 1-1/2” outlet, be made of Pyrolite, have pistol grip and integrated 1-1/4” smoothbore.
- 11.4.9.4.** \_\_\_\_\_ The style 1417 plain tip shall have an orifice of 1-1/8”.
- 11.4.10.** \_\_\_\_\_ Gated Akron brass 2-1/2” hydrant wye style 1582 made of Pyrolite material, consisting of one (1) 2-1/2” female swivel inlet and two (2) 2-1/2” male outlets.
- 11.4.10.1.** \_\_\_\_\_ A quantity of seven (7).
- 11.4.10.2.** \_\_\_\_\_ Shall include a manufacturer’s warranty for a minimum duration of five (5) years.
- 11.4.10.3.** \_\_\_\_\_ Shall utilize self-locking Tork-lok handles for positive handle positioning.

# Bid Submittal Form

a form required of Bidders and Proposers on purchases of supplies, materials, equipment and services for the

## City of Franklin, Tennessee

Purchasing Office Solicitation No.: 2015-017

| <b>Vendor's name, street address, and mailing address:</b>  | <hr/> <hr/> <hr/> <hr/>   |                    |                   |          |                   |  |  |        |   |  |    |      |                   |          |                        |                   |                        |                    |        |   |  |    |      |                   |          |                        |                   |                        |                    |        |   |                   |    |      |                   |          |         |   |                   |   |      |                   |          |                              |
|---|---|--------------------|-------------------|----------|-------------------|--|--|--------|---|--|----|------|-------------------|----------|------------------------|-------------------|------------------------|--------------------|--------|---|--|----|------|-------------------|----------|------------------------|-------------------|------------------------|--------------------|--------|---|-------------------|----|------|-------------------|----------|---------|---|-------------------|---|------|-------------------|----------|------------------------------|
| <b>Vendor's contact person's name (printed), title, telephone number and e-mail address:</b>  | <hr/> <hr/> <hr/> <hr/>   |                    |                   |          |                   |  |  |        |   |  |    |      |                   |          |                        |                   |                        |                    |        |   |  |    |      |                   |          |                        |                   |                        |                    |        |   |                   |    |      |                   |          |         |   |                   |   |      |                   |          |                              |
| <b>Does the bidder take any exceptions to the City's procurement solicitation?</b>  | <input type="checkbox"/> Yes, see enclosed.<br><input type="checkbox"/> No, bidder takes no exceptions.           |                    |                   |          |                   |  |  |        |   |  |    |      |                   |          |                        |                   |                        |                    |        |   |  |    |      |                   |          |                        |                   |                        |                    |        |   |                   |    |      |                   |          |         |   |                   |   |      |                   |          |                              |
| <b>Are exceptions, if any, to the City's procurement solicitation listed separately, described, compared to the City's intention as expressed and implied by the City's solicitation documents and submitted?</b>   | <input type="checkbox"/> Yes, see enclosed.<br><input type="checkbox"/> No, bidder takes no exceptions.           |                    |                   |          |                   |  |  |        |   |  |    |      |                   |          |                        |                   |                        |                    |        |   |  |    |      |                   |          |                        |                   |                        |                    |        |   |                   |    |      |                   |          |         |   |                   |   |      |                   |          |                              |
| <b>Bid warranty duration and pricing for all specified hardware:</b>  |   |                    |                   |          |                   |  |  |        |   |  |    |      |                   |          |                        |                   |                        |                    |        |   |  |    |      |                   |          |                        |                   |                        |                    |        |   |                   |    |      |                   |          |         |   |                   |   |      |                   |          |                              |
| <table border="1" style="width: 100%; border-collapse: collapse;"> <thead> <tr> <th style="width: 10%;">Speci-<br/>fication<br/>No.</th> <th style="width: 30%;">Description</th> <th style="width: 20%;">Warranty Duration</th> <th style="width: 10%;">Quantity</th> <th style="width: 5%;">Units</th> <th style="width: 15%;">Unit Price</th> <th style="width: 10%;">Extended Price<br/>(Quantity multiplied<br/>by Unit Price)</th> </tr> </thead> <tbody> <tr> <td rowspan="3" style="text-align: center; vertical-align: middle;">11.4.7</td> <td>Akron Brass 1-1/2" break-apart nozzles, including ...</td> <td></td> <td rowspan="3" style="text-align: center; vertical-align: middle;">46</td> <td rowspan="3" style="text-align: center; vertical-align: middle;">Each</td> <td rowspan="3" style="text-align: center; vertical-align: middle;">\$ _____ per each</td> <td rowspan="3" style="text-align: center; vertical-align: middle;">\$ _____</td> </tr> <tr> <td>... Style 2431 shutoff</td> <td style="text-align: center;">_____ (=&gt; 5 yrs.)</td> </tr> <tr> <td>... Style 4866 fog tip</td> <td style="text-align: center;">_____ (=&gt; 10 yrs.)</td> </tr> <tr> <td rowspan="3" style="text-align: center; vertical-align: middle;">11.4.8</td> <td>Akron Brass 2-1/2" break-apart nozzles, including ...</td> <td></td> <td rowspan="3" style="text-align: center; vertical-align: middle;">12</td> <td rowspan="3" style="text-align: center; vertical-align: middle;">Each</td> <td rowspan="3" style="text-align: center; vertical-align: middle;">\$ _____ per each</td> <td rowspan="3" style="text-align: center; vertical-align: middle;">\$ _____</td> </tr> <tr> <td>... Style 2433 shutoff</td> <td style="text-align: center;">_____ (=&gt; 5 yrs.)</td> </tr> <tr> <td>... Style 4824 fog tip</td> <td style="text-align: center;">_____ (=&gt; 10 yrs.)</td> </tr> <tr> <td style="text-align: center; vertical-align: middle;">11.4.9</td> <td>Akron Brass 2-1/2" break-apart nozzles, consisting of a Style 2433 shutoff and a Style 1417 plain tip</td> <td style="text-align: center;">_____ (=&gt; 5 yrs.)</td> <td style="text-align: center; vertical-align: middle;">14</td> <td style="text-align: center; vertical-align: middle;">Each</td> <td style="text-align: center; vertical-align: middle;">\$ _____ per each</td> <td style="text-align: center; vertical-align: middle;">\$ _____</td> </tr> <tr> <td style="text-align: center; vertical-align: middle;">11.4.10</td> <td>Gated Akron brass 2-1/2" hydrant wye Style 1582</td> <td style="text-align: center;">_____ (=&gt; 5 yrs.)</td> <td style="text-align: center; vertical-align: middle;">7</td> <td style="text-align: center; vertical-align: middle;">Each</td> <td style="text-align: center; vertical-align: middle;">\$ _____ per each</td> <td style="text-align: center; vertical-align: middle;">\$ _____</td> </tr> </tbody> </table> | Speci-<br>fication<br>No.   | Description        | Warranty Duration | Quantity | Units             | Unit Price   | Extended Price<br>(Quantity multiplied<br>by Unit Price) | 11.4.7 | Akron Brass 1-1/2" break-apart nozzles, including ... |  | 46 | Each | \$ _____ per each | \$ _____ | ... Style 2431 shutoff | _____ (=> 5 yrs.) | ... Style 4866 fog tip | _____ (=> 10 yrs.) | 11.4.8 | Akron Brass 2-1/2" break-apart nozzles, including ... |  | 12 | Each | \$ _____ per each | \$ _____ | ... Style 2433 shutoff | _____ (=> 5 yrs.) | ... Style 4824 fog tip | _____ (=> 10 yrs.) | 11.4.9 | Akron Brass 2-1/2" break-apart nozzles, consisting of a Style 2433 shutoff and a Style 1417 plain tip | _____ (=> 5 yrs.) | 14 | Each | \$ _____ per each | \$ _____ | 11.4.10 | Gated Akron brass 2-1/2" hydrant wye Style 1582 | _____ (=> 5 yrs.) | 7 | Each | \$ _____ per each | \$ _____ | <b>Grand total:</b> \$ _____ |
| Speci-<br>fication<br>No.   | Description   | Warranty Duration  | Quantity          | Units    | Unit Price        | Extended Price<br>(Quantity multiplied<br>by Unit Price) |  |        |   |  |    |      |                   |          |                        |                   |                        |                    |        |   |  |    |      |                   |          |                        |                   |                        |                    |        |   |                   |    |      |                   |          |         |   |                   |   |      |                   |          |                              |
| 11.4.7  | Akron Brass 1-1/2" break-apart nozzles, including ...   |                    | 46                | Each     | \$ _____ per each | \$ _____   |  |        |   |  |    |      |                   |          |                        |                   |                        |                    |        |   |  |    |      |                   |          |                        |                   |                        |                    |        |   |                   |    |      |                   |          |         |   |                   |   |      |                   |          |                              |
|   | ... Style 2431 shutoff  | _____ (=> 5 yrs.)  |                   |          |                   |  |  |        |   |  |    |      |                   |          |                        |                   |                        |                    |        |   |  |    |      |                   |          |                        |                   |                        |                    |        |   |                   |    |      |                   |          |         |   |                   |   |      |                   |          |                              |
|   | ... Style 4866 fog tip  | _____ (=> 10 yrs.) |                   |          |                   |  |  |        |   |  |    |      |                   |          |                        |                   |                        |                    |        |   |  |    |      |                   |          |                        |                   |                        |                    |        |   |                   |    |      |                   |          |         |   |                   |   |      |                   |          |                              |
| 11.4.8  | Akron Brass 2-1/2" break-apart nozzles, including ...   |                    | 12                | Each     | \$ _____ per each | \$ _____   |  |        |   |  |    |      |                   |          |                        |                   |                        |                    |        |   |  |    |      |                   |          |                        |                   |                        |                    |        |   |                   |    |      |                   |          |         |   |                   |   |      |                   |          |                              |
|   | ... Style 2433 shutoff  | _____ (=> 5 yrs.)  |                   |          |                   |  |  |        |   |  |    |      |                   |          |                        |                   |                        |                    |        |   |  |    |      |                   |          |                        |                   |                        |                    |        |   |                   |    |      |                   |          |         |   |                   |   |      |                   |          |                              |
|   | ... Style 4824 fog tip  | _____ (=> 10 yrs.) |                   |          |                   |  |  |        |   |  |    |      |                   |          |                        |                   |                        |                    |        |   |  |    |      |                   |          |                        |                   |                        |                    |        |   |                   |    |      |                   |          |         |   |                   |   |      |                   |          |                              |
| 11.4.9  | Akron Brass 2-1/2" break-apart nozzles, consisting of a Style 2433 shutoff and a Style 1417 plain tip             | _____ (=> 5 yrs.)  | 14                | Each     | \$ _____ per each | \$ _____   |  |        |   |  |    |      |                   |          |                        |                   |                        |                    |        |   |  |    |      |                   |          |                        |                   |                        |                    |        |   |                   |    |      |                   |          |         |   |                   |   |      |                   |          |                              |
| 11.4.10   | Gated Akron brass 2-1/2" hydrant wye Style 1582   | _____ (=> 5 yrs.)  | 7                 | Each     | \$ _____ per each | \$ _____   |  |        |   |  |    |      |                   |          |                        |                   |                        |                    |        |   |  |    |      |                   |          |                        |                   |                        |                    |        |   |                   |    |      |                   |          |         |   |                   |   |      |                   |          |                              |
| <b>Are the City's preferred delivery terms (FOB destination, freight prepaid and added) acceptable to bidder?</b>   | <input type="checkbox"/> Yes.<br><input type="checkbox"/> No, bidder requests the following delivery terms: _____ |                    |                   |          |                   |  |  |        |   |  |    |      |                   |          |                        |                   |                        |                    |        |   |  |    |      |                   |          |                        |                   |                        |                    |        |   |                   |    |      |                   |          |         |   |                   |   |      |                   |          |                              |
| <b>Are the City's preferred payment terms (net 30 days from date of delivery or date of invoice, whichever is later) acceptable to bidder?</b>  | <input type="checkbox"/> Yes.<br><input type="checkbox"/> No, bidder requests the following payment terms: _____  |                    |                   |          |                   |  |  |        |   |  |    |      |                   |          |                        |                   |                        |                    |        |   |  |    |      |                   |          |                        |                   |                        |                    |        |   |                   |    |      |                   |          |         |   |                   |   |      |                   |          |                              |

# Bid Submittal Form

a form required of Bidders and Proposers on purchases of supplies, materials, equipment and services for the

## City of Franklin, Tennessee

Purchasing Office Solicitation No.: 2015-017

|   |  |
|---|--|
| <b>Vendor's name:</b>   | _____  |
| <b>Estimated time of delivery:</b>  | _____ days after receipt of order.   |
| <b>Last date (no sooner than February 28, 2015) that bid and associated pricing is valid and may be accepted by the City:</b>   | _____  |
| <b>Last date (no sooner than July 31, 2015) that bid pricing on a per unit basis is valid for potential future orders:</b>  | _____  |
| <b>Method of payment</b> – The City prefers to pay its vendors electronically, either by direct deposit (i.e., “ACH” or “Electronic Funds Transfer”), or by Visa credit card, rather than by conventional check. Which payment method would the bidder prefer?  | <input type="checkbox"/> ACH or Electronic Funds Transfer.<br><input type="checkbox"/> Visa credit card.   |
| <b>Are the following included with this Bid Submittal Form in the bid submittal?</b> <ul style="list-style-type: none"> <li>• Detailed vendor-supplied description of bid product(s) or item(s);</li> <li>• Detailed vendor-supplied description of the warranties included in the pricing;</li> <li>• City of Franklin specifications for this procurement, marked by the bidder as to compliance therewith as per the instructions therein;</li> <li>• Detailed vendor-supplied identification, listing and description of any exceptions to the written specifications as per the instructions therefor;</li> <li>• Vendor-supplied contact information for minimum of three references;</li> <li>• City of Franklin Standard Procurement Terms and Conditions, with the vendor's contact information inserted;</li> <li>• Vendor proposed terms and conditions, if any, that are not inconsistent with the City's Standard Procurement Terms and Conditions; and</li> <li>• City of Franklin Affidavit of Non-Collusion, executed in full.</li> </ul> | <input type="checkbox"/> Yes, see enclosed.<br><br><input type="checkbox"/> No, bidder chooses not to include all of these documents (NOTE: doing so may cause the City to deem the bid non-responsive). |
| <b>Receipt acknowledged of any and all issued addenda to this solicitation:</b>   | <input type="checkbox"/> Addendum No. _____ received.<br><input type="checkbox"/> Addenda Nos. _____ received.<br><input type="checkbox"/> No addenda received.  |
| <b>Signature of bidder's authorized representative:</b> I have received and read, and do understand and consent, to all instructions, terms and conditions, including those imposed by reference, which apply to this procurement solicitation and compliance with which is required as a condition precedent to consideration of the bid submitted herewith.   | _____<br><div style="text-align: center;">(signature)</div>  |
| <b>Title of bidder's authorized representative:</b>   | _____  |
| <b>Date of signature:</b>   | _____  |



# Affidavit of Non-Collusion

a form required of Bidders and Proposers on purchases of supplies, materials, equipment and services for the City of Franklin, Tennessee

State of \_\_\_\_\_ )  
 ) SS  
County of \_\_\_\_\_ )

Affiant, \_\_\_\_\_, deposes and makes oath that:  
(printed name of person signing Affidavit)

1. He or she is the \_\_\_\_\_ of  
(Owner or Authorized Partner, Officer, Representative or Agent of Owner)  
\_\_\_\_\_  
(legal name of entity submitting bid or proposal)

the Bidder or Proposer who has submitted the attached bid or proposal;

- 2. The Bidder or Proposer is fully informed respecting the preparation and content of the attached bid or proposal and of all pertinent circumstances respecting such bid or proposal;
- 3. Such bid or proposal is genuine and is not a collusive or sham bid or proposal;
- 4. Neither the said Bidder or Proposer nor any of its officers, partners, owners, agents, representatives, employees, or parties in interest, including this Affiant, has in any way colluded, conspired, connived or agreed, directly or indirectly, with any official or agent of the City of Franklin or with any other firm, person, or potential or actual bidder or proposer to submit a collusive or sham bid or proposal in connection with the contract for which the attached bid or proposal has been submitted, or to refrain from bidding or proposing indirectly, or sought by agreement, or collusion, or communication, or conference with any other firm, person, or potential or actual bidder or proposer to fix the price or prices or cost element of the bid, quoted or proposed price or the bid, quoted or proposed price of any other potential or actual bidder or proposer, or to secure through any collusion, conspiracy, connivance, or unlawful agreement any advantage against the City of Franklin or any person interested in the proposed contract;
- 5. The price or prices quoted in the attached bid or proposal are fair and proper and are not tainted by a collusion, conspiracy, connivance, or unlawful agreement on the part of the Bidder or Proposer or any of its agents, representatives, owners, employees, or parties in interest, including this Affiant; and
- 6. He or she understands that Article VIII, Section 16, of the City Charter of Franklin, and T.C.A. §6-54-107, prohibit any member of the Board of Mayor and Aldermen, or officer elected by said Board, from being interested in any contract, or work of any kind whatever, under its control and direction, and any contract in which any such person shall have an interest shall be void and unenforceable, subjecting any funds received by contractor to be returned in full to the City, in addition to any other penalties provided by law.

\_\_\_\_\_  
(signature of Affiant) (title of Affiant)

Sworn and subscribed to before me this \_\_\_\_\_ day of \_\_\_\_\_, 20\_\_\_\_\_

\_\_\_\_\_  
(Notary Public) My Commission Expires: \_\_\_\_\_

(Submitted in response to City of Franklin Purchasing Office Solicitation No. \_\_\_\_\_ - \_\_\_\_\_)

# Standard Procurement Terms and Conditions

## City of Franklin, Tennessee

---

1. Assignment/Subcontracting. Neither party may assign any rights or obligations under these Standard Procurement Terms and Conditions or any Statement of Work without the prior written consent of the other party. These Standard Procurement Terms and Conditions will be binding upon and inure to the benefit of the parties and their respective successors and permitted assigns. Vendor may subcontract any portion of the work only with the prior consent of the City, but such subcontracting will not relieve Vendor of its duties under these Standard Procurement Terms and Conditions.
  
2. Time of the Essence. The parties agree that TIME IS OF THE ESSENCE with respect to the vendor's performance of all provisions of this procurement.
  
3. Taxes. As a tax-exempt entity, the City shall not be responsible for sales or use taxes incurred for products or services. Upon request, the City shall supply Vendor with a copy of its Sales and Use Tax Exemption Certificate. Vendor shall bear the burden of providing its suppliers with a copy of the City's tax exemption certificate and shall assume all liability for such taxes, if any, that should be incurred.
  
4. Notices. Any notice provided pursuant to these Standard Procurement Terms and Conditions, if specified to be in writing, will be in writing and will be deemed given: (a) if by hand delivery, then upon receipt thereof; (b) if mailed, then three (3) City business days after deposit in the mail where sender is located, postage prepaid, certified mail return receipt requested; (c) if by next day delivery service, then upon such delivery; or (d) if by facsimile transmission or electronic mail, then upon confirmation of receipt. All notices will be addressed to the parties at the addresses set forth below (or set forth in such other document which these Standard Procurement Terms and Conditions may accompany, or such other address as either party may in the future specify in writing to the other):

In the case of the City:

In the case of Vendor:

City of Franklin

\_\_\_\_\_

Attn: Purchasing Manager

\_\_\_\_\_

Re: City of Franklin Purchasing Office Solicitation No. \_\_\_\_\_ - \_\_\_\_\_

109 Third Ave. South

\_\_\_\_\_

P.O. Box 305

\_\_\_\_\_

Franklin, TN 37065-0305

\_\_\_\_\_

FAX: 615/550-0079

\_\_\_\_\_

E-mail: [purchasing@franklintn.gov](mailto:purchasing@franklintn.gov)

\_\_\_\_\_

# Standard Procurement Terms and Conditions

## City of Franklin, Tennessee

---

5. Confidentiality and Proprietary rights. Vendor waives any right to confidentiality of any document, e-mail or file it fails to clearly mark on each page (or section as the case may be) as confidential or proprietary. Proprietary rights do not extend to the data created by the City's users of the System; all rights to that data (including derivative or hidden data such as metadata) shall vest solely in City at the moment of creation and City shall retain exclusive rights, title, and ownership of all data and images created therefrom at the moment of creation and utilization, through and including image creation. City may be required to disclose documents under state or federal law. City shall notify Vendor if a request for documents has been made and shall give Vendor a reasonable opportunity under the circumstances to respond to the request by redacting proprietary or other confidential information. In exchange, Vendor agrees to indemnify, defend, and hold harmless City for any claims by third parties relating thereto or arising out of (i) the City's failure to disclose such documents or information required to be disclosed by law, or (ii) the City's release of documents as a result of City's reliance upon Vendor's representation that materials supplied by Vendor (in full or redacted form) do not contain trade secrets or proprietary information, provided that the City impleads Vendor and Vendor assumes control over that claim.
6. Derivative Works. To the extent that the Agreement contains Vendor's reservation of rights, such definitions and limitations are superseded by the following: "Derivative Work" means a program that is based on or derived from one or more existing programs or components. If the original software is modified to create a new program, a derived work is created. If the original software was designed to accept plug-ins or drivers using a defined mechanism, such a driver or plug-in does not form a derived work. Linking to a library in the way it was designed to be interfaced with, does *not* constitute deriving a work. "Derivative work" is *not* the data that the Licensee inputs, manipulates, modifies or otherwise improves, nor the images resulting therefrom.
7. Arbitration/Mediation. No arbitration shall be required as a condition precedent to filing any legal claim arising out of or relating to the Contract. No arbitration or mediation shall be binding.
8. Waiver. Neither party's failure or delay to exercise any of its rights or powers under these Standard Procurement Terms and Conditions will constitute or be deemed a waiver or forfeiture of those rights or powers. For a waiver of a right or power to be effective, it must be in writing signed by the waiving party. An effective waiver of a right or power shall not be construed as either (a) a future or continuing waiver of that same right or power, or (b) the waiver of any other right or power.
9. Warranties/Limitation of Liability/Waiver. City reserves all rights afforded to local governments under law for all general and implied warranties. The City does not waive any rights it may have to all remedies provided by law and therefore any attempt by Vendor to limit its liability shall be void and unenforceable.
10. Severability. If any term or provision of these Standard Procurement Terms and Conditions is held to be illegal or unenforceable, the validity or enforceability of the remainder of these Standard Procurement Terms and Conditions will not be affected.

# Standard Procurement Terms and Conditions

## City of Franklin, Tennessee

---

11. Precedence. In the event of conflict between the provisions of these Standard Procurement Terms and Conditions and any contract, agreement or other document which these Standard Procurement Terms and Conditions may accompany, the provisions of these Standard Procurement Terms and Conditions will to the extent of such conflict take precedence unless such document expressly states that it is amending these Standard Procurement Terms and Conditions.
12. Indemnification. Vendor agrees to indemnify and save the Government of Franklin, the City of Franklin and individual, on or off duty, officers, and employees of the City of Franklin, harmless from any and all losses, damages and expenses, including court costs and attorneys' fees, by reason of any loss, whatsoever, arising out of or relating to or in consequence of the work done in connection with the contract of which this agreement is a part, excepting only such losses as shall be occasioned solely by the negligence of the City of Franklin.
13. Additions/Modifications. If seeking any addition or modification to the Contract, the parties agree to reference the specific paragraph number sought to be changed on any future document or purchase order issued in furtherance of the Contract, however, an omission of the reference to same shall not affect its applicability. In no event shall either party be bound by any terms contained in any purchase order, acknowledgement, or other writings unless: (a) such purchase order, acknowledgement, or other writings specifically refer to the Contract or to the specific clause they are intended to modify; (b) clearly indicate the intention of both parties to override and modify the Contract; and (c) such purchase order, acknowledgement, or other writings are signed, with specific material clauses separately initialed, by authorized representatives of both parties.
14. Applicable Law; Choice of Forum/Venue. These Standard Procurement Terms and Conditions are made under and will be construed in accordance with the laws of the State of Tennessee without giving effect to any state's choice-of-law rules. The choice of forum and venue shall be exclusively in the Courts of Williamson County, TN.
15. Termination. Unless the City has indicated otherwise for a specific procurement solicitation, either party may terminate these Standard Procurement Terms and Conditions, with or without cause, upon thirty (30) calendar days' notice to the other. Upon termination by the vendor, the City shall be entitled to retain ownership of any and all goods and equipment purchased. Upon termination by the City, the vendor shall be entitled to receive any amounts due as a result of goods and equipment already delivered and/or services already rendered; however, the City shall maintain ownership and control of any goods and equipment purchased. Upon termination of services, whether connected or unconnected to goods and equipment, such services shall be rendered until the conclusion of the 30<sup>th</sup> calendar day as stated in the notice or until a contractual benchmark has been achieved, or as the parties may otherwise agree.

# Standard Procurement Terms and Conditions

## City of Franklin, Tennessee

---

16. Breach. Upon deliberate breach of these Standard Procurement Terms and Conditions, or of any contract, agreement or other document which these Standard Procurement Terms and Conditions may accompany, by either party, the non-breaching party shall be entitled to terminate these Standard Procurement Terms and Conditions without notice, with all of the remedies it would have in the event of termination under section 10 (“Severability”) above, and may also have such other remedies as it may be entitled to in law or in equity.
17. Default. If Vendor fails to perform or comply with any provision of these Standard Procurement Terms and Conditions, or of any contract, agreement or other document which these Standard Procurement Terms and Conditions may accompany, then the City (i) may cancel the purchase award and/or the accompanying contract or agreement or purchase order, in whole or in part, without penalty or protest by Vendor; (ii) may consider such failure to perform or comply as a breach of contract; (iii) reserves the right to purchase its requirements from the vendor that submitted the next lowest and best responsive and responsible bid, or the vendor that submitted the next best proposal, if that vendor will still honor that bid or proposal, or to seek new bids or proposals, or to pursue one or more other options available to the City in compliance with its then current purchasing policy; and (iv) may hold the defaulting vendor liable for all damages provided by law, including cost of cover.
18. Entire Agreement. These Standard Procurement Terms and Conditions, including any contract, agreement or other document which these Standard Procurement Terms and Conditions may accompany, constitutes the entire agreement between the parties and supersedes any prior or contemporaneous communications, representations or agreements between the parties, whether oral or written, regarding the subject matter of these Standard Procurement Terms and Conditions. The terms and conditions of these Standard Procurement Terms and Conditions may not be changed except by an amendment expressly referencing these Standard Procurement Terms and Conditions by section number and signed by an authorized representative of each party.
19. Survival. These Standard Procurement Terms and Conditions shall survive the completion of or any termination of any contract, agreement or other document which these Standard Procurement Terms and Conditions may accompany.

**CITY OF FRANKLIN, TENNESSEE**  
**PROCUREMENT AGREEMENT**  
(City of Franklin Contract No. 2014-0346)

---

**Attachment No. 2**

SUBMITTAL

## Bid Submittal Form

a form required of Bidders and Proposers on purchases of supplies, materials, equipment and services for the  
**City of Franklin, Tennessee**

Purchasing Office Solicitation No.: 2015-017

| <b>Vendor's name, street address, and mailing address:</b>  | NORTH AMERICA FIRE EQUIPMENT CO., INC.<br>(NAFECO)<br>1515 West Moulton Street<br>Decatur, AL 35601                |                          |          |  |                             |  |
|---|--|--------------------------|----------|--|-----------------------------|--|
| <b>Vendor's contact person's name (printed), title, telephone number and e-mail address:</b>  | Ronald Woodall, Vice President<br>800-628-6233<br>ronald.woodall@nafeco.com  |                          |          |  |                             |  |
| <b>Does the bidder take any exceptions to the City's procurement solicitation?</b>  | <input type="checkbox"/> Yes, see enclosed.<br><input checked="" type="checkbox"/> No, bidder takes no exceptions. |                          |          |  |                             |  |
| <b>Are exceptions, if any, to the City's procurement solicitation listed separately, described, compared to the City's intention as expressed and implied by the City's solicitation documents and submitted?</b> | <input type="checkbox"/> Yes, see enclosed.<br><input checked="" type="checkbox"/> No, bidder takes no exceptions. |                          |          |  |                             |  |
| <b>Bid warranty duration and pricing for all specified hardware:</b>  |  |                          |          |  |                             |  |
| Speci-<br>fication<br>No.   | Description  | Warranty Duration        | Quantity | Units  | Unit Price                  | Extended Price<br>(Quantity multiplied<br>by Unit Price) |
| 11.4.7  | Akron Brass 1-1/2" break-apart nozzles, including ...  |                          | 46       | Each   | \$ <u>699.97</u> per each   | \$ <u>32,198.62</u>                                      |
|   | ... Style 2431 shutoff   | <u>5Yr</u> (=> 5 yrs.)   |          |  |                             |  |
|   | ... Style 4866 fog tip   | <u>10Yr</u> (=> 10 yrs.) |          |  |                             |  |
| 11.4.8  | Akron Brass 2-1/2" break-apart nozzles, including ...  |                          | 12       | Each   | \$ <u>849.94</u> per each   | \$ <u>10,199.28</u>                                      |
|   | ... Style 2433 shutoff   | <u>5Yr</u> (=> 5 yrs.)   |          |  |                             |  |
|   | ... Style 4824 fog tip   | <u>10Yr</u> (=> 10 yrs.) |          |  |                             |  |
| 11.4.9  | Akron Brass 2-1/2" break-apart nozzles, consisting of a Style 2433 shutoff and a Style 1417 plain tip              | <u>5Yr</u> (=> 5 yrs.)   | 14       | Each   | \$ <u>478.66</u> per each   | \$ <u>6,701.24</u>                                       |
| 11.4.10   | Gated Akron brass 2-1/2" hydrant wye Style 1582  | <u>5Yr</u> (=> 5 yrs.)   | 7        | Each   | \$ <u>1,073.60</u> per each | \$ <u>7,515.20</u>                                       |
| <b>Grand total:</b>   |  |                          |          |  |                             | \$ <u>56,614.34</u>                                      |
| <b>Are the City's preferred delivery terms (FOB destination, freight prepaid and added) acceptable to bidder?</b>   |  |                          |          | <input checked="" type="checkbox"/> Yes.<br><input type="checkbox"/> No, bidder requests the following delivery terms: _____ |                             |  |
| <b>Are the City's preferred payment terms (net 30 days from date of delivery or date of invoice, whichever is later) acceptable to bidder?</b>  |  |                          |          | <input checked="" type="checkbox"/> Yes.<br><input type="checkbox"/> No, bidder requests the following payment terms: _____  |                             |  |

## Bid Submittal Form

a form required of Bidders and Proposers on purchases of supplies, materials, equipment and services for the  
**City of Franklin, Tennessee**

Purchasing Office Solicitation No.: 2015-017

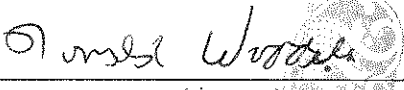
|   |   |
|---|---|
| <b>Vendor's name:</b>   | <u>NAFECO</u>   |
| <b>Estimated time of delivery:</b>  | <u>(30)</u> days after receipt of order.  |
| <b>Last date (no sooner than February 28, 2015) that bid and associated pricing is valid and may be accepted by the City:</b>   | <u>July 31, 2015</u>  |
| <b>Last date (no sooner than July 31, 2015) that bid pricing on a per unit basis is valid for potential future orders:</b>  | <u>July 31, 2015</u>  |
| <b>Method of payment</b> – The City prefers to pay its vendors electronically, either by direct deposit (i.e., “ACH” or “Electronic Funds Transfer”), or by Visa credit card, rather than by conventional check. Which payment method would the bidder prefer?  | <input checked="" type="checkbox"/> ACH or Electronic Funds Transfer.<br><input type="checkbox"/> Visa credit card.   |
| <b>Are the following included with this Bid Submittal Form in the bid submittal?</b> <ul style="list-style-type: none"> <li>• Detailed vendor-supplied description of bid product(s) or item(s);</li> <li>• Detailed vendor-supplied description of the warranties included in the pricing;</li> <li>• City of Franklin specifications for this procurement, marked by the bidder as to compliance therewith as per the instructions therein;</li> <li>• Detailed vendor-supplied identification, listing and description of any exceptions to the written specifications as per the instructions therefor;</li> <li>• Vendor-supplied contact information for minimum of three references;</li> <li>• City of Franklin Standard Procurement Terms and Conditions, with the vendor's contact information inserted;</li> <li>• Vendor proposed terms and conditions, if any, that are not inconsistent with the City's Standard Procurement Terms and Conditions; and</li> <li>• City of Franklin Affidavit of Non-Collusion, executed in full.</li> </ul> | <input checked="" type="checkbox"/> Yes, see enclosed.<br><br><input type="checkbox"/> No, bidder chooses not to include all of these documents (NOTE: doing so may cause the City to deem the bid non-responsive). |
| <b>Receipt acknowledged of any and all issued addenda to this solicitation:</b>   | <input type="checkbox"/> Addendum No. _____ received.<br><input type="checkbox"/> Addenda Nos. _____ received.<br><input checked="" type="checkbox"/> No addenda received.  |
| <b>Signature of bidder's authorized representative:</b> I have received and read, and do understand and consent, to all instructions, terms and conditions, including those imposed by reference, which apply to this procurement solicitation and compliance with which is required as a condition precedent to consideration of the bid submitted herewith.   | <br>_____<br>(signature)<br>Ronald Woodall  |
| <b>Title of bidder's authorized representative:</b>   | <u>Vice President</u>   |
| <b>Date of signature:</b>   | <u>12/2/14</u>  |



# City of Franklin Specifications

Purchasing Office Solicitation No.: 2015-017

---

1. Solicitation identified: These specifications apply to the following procurement:  
**supply and delivery of firefighting nozzles and hydrant wyes**  
**Purchasing Office Solicitation No.: 2015-017**
2. Notice to Bidders publication date: **November 20, 2014**
3. Solicitation release date: **November 21, 2014**
4. Deadline for optional submittal in writing of questions seeking to revise or clarify any aspect of this procurement solicitation: **November 25, 2014, 2:00 p.m. Central Time**
5. Bids submittal deadline and scheduled opening: **December 4, 2014, 2:00 p.m. Central Time**
6. Tentative date of release of City's tabulation of bids received and notice of intent to award: **January 9, 2015**
7. Tentative date of award: Meeting of Board of Mayor and Aldermen at which is tentatively scheduled to be awarded the selection of the lowest and best responsive and responsible bid: **January 27, 2015**
8. Objective: To secure, by means of a competitive procurement process, the selection of the lowest and best responsive and responsible bid from a vendor to furnish all materials and means necessary to supply and deliver to the City of Franklin Fire Department firefighting nozzles and hydrant wyes as specified below. See the accompanying Instructions for Bidders for additional information and instructions.
9. Exceptions:
  - a. In order to avoid the need to take an exception to a specification, potential bidders may request revisions to the specifications before the deadline for optional submittal in writing of questions seeking to revise or clarify any aspect of the specifications. See the accompanying Instructions for Bidders for contact information.
  - b. Any deviation or variance from the City's specifications shall be considered to be an exception.
  - c. Any exceptions to the City's specifications shall be identified by the bidder on the City's specifications document as well as listed and described in detail, along with any other exceptions to this procurement solicitation, in a separate written document to be prepared and submitted by the bidder, referencing any subsection number. Such listing

# City of Franklin Specifications

Purchasing Office Solicitation No.: 2015-017

---

shall include a description of exactly how such exceptions deviate from the City's expectations as expressed and implied by the procurement solicitation, and shall indicate why such exceptions should be judged by the City to meet or exceed those expectations. Any and all exceptions to this procurement solicitation which the City, in its sole discretion, deems not to meet or exceed the City's intention as expressed and implied by the procurement solicitation may be considered by the City as a factor in evaluating the bid.

10. General terms and conditions:

- a. Bid price: The bid price shall include all equipment, labor, materials, permit(s), freight and required insurance to supply and deliver the specified products.
- b. Delivery terms: As a matter of practice, the City of Franklin expects vendor to ship any and all deliverables FOB destination, freight prepaid and added. The City's preferred delivery terms, as described in the preceding sentence, are offered to the bidder or proposer as a condition of award. If the City's preferred delivery terms are unacceptable to the bidder or proposer, then the bidder or proposer shall indicate on the Submittal Form its preferred delivery terms. Delivery terms may be a factor in the City's selection criteria. Delivery terms are non-negotiable after award is made.
- c. Payment terms: As a matter of practice, the City of Franklin pays for goods and/or services only after receipt and acceptance by the City of such goods and/or services, and only after receipt of an accurate, proper, complete and itemized invoice for such goods and/or services, net 30 calendar days from date of delivery and/or completion/installation/rendering or date of invoice, whichever is later. The City's preferred payment terms, as described in the preceding sentence, are offered to the bidder or proposer as a condition of award. If the City's preferred payment terms are unacceptable to the bidder or proposer, then the bidder or proposer shall indicate on the Submittal Form its preferred payment terms. Payment terms may be a factor in the City's selection criteria. Payment terms are non-negotiable after award is made.
- d. Applicable laws and regulations: All applicable federal and state laws, city ordinances, orders, rules and regulations of all authorities having jurisdiction over the specified products shall apply to the quoted purchase price, and they will be deemed to be included in these specifications the same as though they are written out in full herein.
- e. Standard Procurement Terms and Conditions: By submitting its bid, the vendor certifies that it has read and accepts all terms, conditions and requirements of this solicitation, including the terms and conditions identified and listed in the City of Franklin Standard Procurement Terms and Conditions attached hereto and hereby incorporated by reference.
- f. Refusal to honor submittal: If and after an award is made by the City, if the vendor refuses to execute an agreement or contract or in any other way honor the terms and conditions of its submittal, the City shall be entitled to seek compensation for its damages, which may include the cost of conducting a new solicitation.

# City of Franklin Specifications

Purchasing Office Solicitation No.: 2015-017

---

- g. Confidential and/or proprietary information; trade secrets. All contents of all submittals are subject to public disclosure and shall not contain any confidential and/or proprietary information and/or trade secrets. Further, by submitting its bid, the vendor indemnifies and holds the City of Franklin harmless against any loss or damage, including reasonable attorney fees, it may incur as a result of the City's reliance upon the vendor's representation that materials supplied by the vendor do not contain trade secrets or proprietary information which is not subject to public disclosure.

11. Detailed specifications: Please note:

- Bidders are required to submit with their bid a detailed description of all bid products and/or items.
- Bidders are required to mark with a "C" the blank line next to any specification below to which their bid COMPLIES.
- Bidders are required to mark with an "E" the blank line next to any specification below to which their bid takes EXCEPTION.
- Any exceptions to the City's specifications shall be identified by the bidder on the City's specifications document as well as listed and described in detail, along with any other exceptions to this procurement solicitation, in a separate written document to be prepared and submitted by the bidder, referencing any subsection number. Such listing shall include a description of exactly how such exceptions deviate from the City's expectations as expressed and implied by the procurement solicitation, and shall indicate why such exceptions should be judged by the City to meet or exceed those expectations.
- Bidders are required to submit with their bid these Specifications for this procurement, marked by the bidder as to compliance herewith as per the instructions above.

**11.1. General.**

- 11.1.1.   C   City intends for the Franklin Fire Department to use the specified nozzles and wyes on firefighting hand lines in the activity of fire suppression. Items as bid shall be designed and manufactured according to industry standards for this intended use.
- 11.1.2.   C   Nozzles and wyes are to be purchased new and unused by the City.
- 11.1.3.   C   Purchased nozzles and wyes shall be of current production only.
- 11.1.4.   C   The quantities of items to be ordered upon award of the bid are noted below. However, quoted bid prices are to be offered by the bidder on a per unit basis for potential future orders at least through July 31, 2015 and until the date indicated on the bidder's Bid Submittal Form as the "last date that bid price on a per unit basis is valid for potential future orders," up to when the specified item is no longer available for purchase new.

# City of Franklin Specifications

Purchasing Office Solicitation No.: 2015-017

---

- 11.2. Warranty.**
- 11.2.1. C Manufacturer's warranty, for durations not less than the durations indicated below, shall be included in the bid.
- 11.2.2. C Bidder shall indicate the durations of the manufacturer's warranty on the Bid Submittal Form.
- 11.2.3. C Bidder shall supply a description of the manufacturer's warranty along with the Bid Submittal Form.
- 11.3. Delivery, Documentation and Training.**
- 11.3.1. C Vendor shall indicate on the Bid Submittal Form the estimated time of delivery, measured in number of calendar days after receipt of order.
- 11.3.2. C Vendor specifically acknowledges and accepts City's standard delivery terms as expressed under "General terms and conditions" above.
- 11.3.3. C Vendor shall include delivery and unloading or offloading and deposit of the nozzles and wyes at the following location:  
City of Franklin Fire Department Headquarters  
Franklin City Hall  
109 3<sup>rd</sup> Ave. South  
Franklin, TN 37064
- 11.3.4. C Vendor shall provide any labor and equipment necessary to unload or offload the deliverable in a manner (a) consistent with best practices for shipping and receiving, (b) that does not involve undue risk to the safety of anyone at the delivery site or the condition of the deliverable, (c) that does not involve City personnel, and (d) without the need for a loading dock.
- 11.3.5. C Delivery shall be made between the hours of 7:00 a.m. and 3:30 p.m., Monday through Friday except holidays observed by the City.
- 11.3.6. C Documentation, including both operator and service manuals, warranties, detailed troubleshooting information, and any available unit-specific training videos, shall be provided upon delivery of unit.
- 11.3.7. C Training by a qualified product manufacturer representative shall be provided within 30 days of delivery of the nozzles and wyes.
- 11.3.8. C Training shall be delivered in a minimum of three (3) three-hour sessions on three (3) separate days to be scheduled on days mutually acceptable to the City and the manufacturer's representative.

# City of Franklin Specifications

Purchasing Office Solicitation No.: 2015-017

---

- 11.3.9. C Training shall include both detailed instruction and hands-on demonstrations of the nozzles utilizing a flow meter and piezometer for pumping and handling operation, routine maintenance and routine repair.
- 11.4. **Hardware.**
- 11.4.1. ~~C~~ All nozzle tip pieces utilizing a polymer bumper, all polymer bales and all polymer pistol grips shall be available in a variety of colors. Color options will be made available in any variety and combination of the COF Fire Department's choosing.
- 11.4.2. C All fog tips shall use an interchangeable baffle to control flow.
- 11.4.3. C All valves shall be of full round ball construction.
- 11.4.4. ~~C~~ All threads shall be NST.
- 11.4.5. C All nozzle tips and bases shall be laser etched for internal inventory purposes. Franklin Fire Department will provide to the awarded vendor an inventory number for each piece, maximum 5 characters long.
- 11.4.6. C All nozzles shall be maintainable by routine maintenance only. Routine maintenance defined as cleaning, not involving disassembling the nozzle, other than break-apart pieces, or any pieces of it. No lubrication shall be required to maintain any part of the nozzle base or tip.
- 11.4.7. C Akron Brass 1-1/2" break-apart nozzles, consisting of a Style 2431 shutoff and a Style 4866 fog tip, for each nozzle.
- 11.4.7.1. ~~C~~ A quantity of forty-six (46).
- 11.4.7.2. C The Style 2431 Saber Shutoff shall have a 1-1/2" inlet and 1-1/2" outlet, be made of Pyrolite, have pistol grip and integrated 15/16" smoothbore, and shall include a manufacturer's warranty for a minimum duration of five (5) years.
- 11.4.7.3. C The Style 4866 Assault fixed orifice fog tip shall be calibrated to 175 GPM at 50 PSI, have a 1-1/2" swivel inlet, be made of Pyrolite, and shall include a manufacturer's warranty for a minimum duration of ten (10) years.
- 11.4.7.4. C The fog nozzle shall be equipped with spinning teeth, ¼ turn quick change adjustment from straight stream to fog pattern and raised lug to indicate fog pattern location.

# City of Franklin Specifications

Purchasing Office Solicitation No.: 2015-017

---

- 11.4.8. C Akron Brass 2-1/2" break-apart nozzles, consisting of a Style 2433 shutoff and a Style 4824 fog tip, for each nozzle.
- 11.4.8.1. C A quantity of twelve (12).
- 11.4.8.2. C The Style 2433 Saber Shutoff shall have a 2-1/2" inlet and 1-1/2" outlet, be made of Pyrolite, have pistol grip and integrated 1-1/4" smoothbore, and shall include a manufacturer's warranty for a minimum duration of five (5) years.
- 11.4.8.3. C The Style 4824 High-Range Assault fixed orifice fog tip shall be calibrated to 250 GPM at 50 PSI, have a 1-1/2" swivel inlet, be made of Pyrolite, and shall include a manufacturer's warranty for a minimum duration of ten (10) years.
- 11.4.8.4. C The fog nozzle shall be equipped with spinning teeth, 1/4 turn quick change adjustment from straight stream to fog pattern and raised lug to indicate fog pattern location.
- 11.4.9. C Akron Brass 2-1/2" break-apart nozzles, consisting of a Style 2433 shutoff and a Style 1417 plain tip, for each nozzle.
- 11.4.9.1. C A quantity of fourteen (14).
- 11.4.9.2. C Shall include a manufacturer's warranty for a minimum duration of five (5) years.
- 11.4.9.3. C The Style 2433 Saber Shutoff shall have a 2-1/2" inlet and 1-1/2" outlet, be made of Pyrolite, have pistol grip and integrated 1-1/4" smoothbore.
- 11.4.9.4. C The style 1417 plain tip shall have an orifice of 1-1/8".
- 11.4.10. C Gated Akron brass 2-1/2" hydrant wye style 1582 made of Pyrolite material, consisting of one (1) 2-1/2" female swivel inlet and two (2) 2-1/2" male outlets.
- 11.4.10.1. C A quantity of seven (7).
- 11.4.10.2. C Shall include a manufacturer's warranty for a minimum duration of five (5) years.
- 11.4.10.3. C Shall utilize self-locking Tork-lok handles for positive handle positioning.

# Standard Procurement Terms and Conditions

## City of Franklin, Tennessee

---

1. Assignment/Subcontracting. Neither party may assign any rights or obligations under these Standard Procurement Terms and Conditions or any Statement of Work without the prior written consent of the other party. These Standard Procurement Terms and Conditions will be binding upon and inure to the benefit of the parties and their respective successors and permitted assigns. Vendor may subcontract any portion of the work only with the prior consent of the City, but such subcontracting will not relieve Vendor of its duties under these Standard Procurement Terms and Conditions.
2. Time of the Essence. The parties agree that TIME IS OF THE ESSENCE with respect to the vendor's performance of all provisions of this procurement.
3. Taxes. As a tax-exempt entity, the City shall not be responsible for sales or use taxes incurred for products or services. Upon request, the City shall supply Vendor with a copy of its Sales and Use Tax Exemption Certificate. Vendor shall bear the burden of providing its suppliers with a copy of the City's tax exemption certificate and shall assume all liability for such taxes, if any, that should be incurred.
4. Notices. Any notice provided pursuant to these Standard Procurement Terms and Conditions, if specified to be in writing, will be in writing and will be deemed given: (a) if by hand delivery, then upon receipt thereof; (b) if mailed, then three (3) City business days after deposit in the mail where sender is located, postage prepaid, certified mail return receipt requested; (c) if by next day delivery service, then upon such delivery; or (d) if by facsimile transmission or electronic mail, then upon confirmation of receipt. All notices will be addressed to the parties at the addresses set forth below (or set forth in such other document which these Standard Procurement Terms and Conditions may accompany, or such other address as either party may in the future specify in writing to the other):

In the case of the City:

City of Franklin  
Attn: Purchasing Manager  
Re: City of Franklin Purchasing Office Solicitation No. \_\_\_\_\_  
109 Third Ave. South  
P.O. Box 305  
Franklin, TN 37065-0305  
FAX: 615/550-0079  
E-mail: [purchasing@franklintn.gov](mailto:purchasing@franklintn.gov)

In the case of Vendor:

**NAFECO**  
**Attn: Ronald Woodall**  
\_\_\_\_\_  
2015\_017  
1515 West Moulton Street  
\_\_\_\_\_  
**Decatur, AL 35601**  
**Fax: 256-355-0852**  
\_\_\_\_\_  
[ronald.woodall@nafeco.com](mailto:ronald.woodall@nafeco.com)

## Standard Procurement Terms and Conditions

### City of Franklin, Tennessee

---

5. Confidentiality and Proprietary rights. Vendor waives any right to confidentiality of any document, e-mail or file it fails to clearly mark on each page (or section as the case may be) as confidential or proprietary. Proprietary rights do not extend to the data created by the City's users of the System; all rights to that data (including derivative or hidden data such as metadata) shall vest solely in City at the moment of creation and City shall retain exclusive rights, title, and ownership of all data and images created therefrom at the moment of creation and utilization, through and including image creation. City may be required to disclose documents under state or federal law. City shall notify Vendor if a request for documents has been made and shall give Vendor a reasonable opportunity under the circumstances to respond to the request by redacting proprietary or other confidential information. In exchange, Vendor agrees to indemnify, defend, and hold harmless City for any claims by third parties relating thereto or arising out of (i) the City's failure to disclose such documents or information required to be disclosed by law, or (ii) the City's release of documents as a result of City's reliance upon Vendor's representation that materials supplied by Vendor (in full or redacted form) do not contain trade secrets or proprietary information, provided that the City impleads Vendor and Vendor assumes control over that claim.
6. Derivative Works. To the extent that the Agreement contains Vendor's reservation of rights, such definitions and limitations are superseded by the following: "Derivative Work" means a program that is based on or derived from one or more existing programs or components. If the original software is modified to create a new program, a derived work is created. If the original software was designed to accept plug-ins or drivers using a defined mechanism, such a driver or plug-in does not form a derived work. Linking to a library in the way it was designed to be interfaced with, does *not* constitute deriving a work. "Derivative work" is *not* the data that the Licensee inputs, manipulates, modifies or otherwise improves, nor the images resulting therefrom.
7. Arbitration/Mediation. No arbitration shall be required as a condition precedent to filing any legal claim arising out of or relating to the Contract. No arbitration or mediation shall be binding.
8. Waiver. Neither party's failure or delay to exercise any of its rights or powers under these Standard Procurement Terms and Conditions will constitute or be deemed a waiver or forfeiture of those rights or powers. For a waiver of a right or power to be effective, it must be in writing signed by the waiving party. An effective waiver of a right or power shall not be construed as either (a) a future or continuing waiver of that same right or power, or (b) the waiver of any other right or power.
9. Warranties/Limitation of Liability/Waiver. City reserves all rights afforded to local governments under law for all general and implied warranties. The City does not waive any rights it may have to all remedies provided by law and therefore any attempt by Vendor to limit its liability shall be void and unenforceable.
10. Severability. If any term or provision of these Standard Procurement Terms and Conditions is held to be illegal or unenforceable, the validity or enforceability of the remainder of these Standard Procurement Terms and Conditions will not be affected.



# Standard Procurement Terms and Conditions

## City of Franklin, Tennessee

---

11. Precedence. In the event of conflict between the provisions of these Standard Procurement Terms and Conditions and any contract, agreement or other document which these Standard Procurement Terms and Conditions may accompany, the provisions of these Standard Procurement Terms and Conditions will to the extent of such conflict take precedence unless such document expressly states that it is amending these Standard Procurement Terms and Conditions.
  
12. Indemnification. Vendor agrees to indemnify and save the Government of Franklin, the City of Franklin and individual, on or off duty, officers, and employees of the City of Franklin, harmless from any and all losses, damages and expenses, including court costs and attorneys' fees, by reason of any loss, whatsoever, arising out of or relating to or in consequence of the work done in connection with the contract of which this agreement is a part, excepting only such losses as shall be occasioned solely by the negligence of the City of Franklin.
  
13. Additions/Modifications. If seeking any addition or modification to the Contract, the parties agree to reference the specific paragraph number sought to be changed on any future document or purchase order issued in furtherance of the Contract, however, an omission of the reference to same shall not affect its applicability. In no event shall either party be bound by any terms contained in any purchase order, acknowledgement, or other writings unless: (a) such purchase order, acknowledgement, or other writings specifically refer to the Contract or to the specific clause they are intended to modify; (b) clearly indicate the intention of both parties to override and modify the Contract; and (c) such purchase order, acknowledgement, or other writings are signed, with specific material clauses separately initialed, by authorized representatives of both parties.
  
14. Applicable Law; Choice of Forum/Venue. These Standard Procurement Terms and Conditions are made under and will be construed in accordance with the laws of the State of Tennessee without giving effect to any state's choice-of-law rules. The choice of forum and venue shall be exclusively in the Courts of Williamson County, TN.
  
15. Termination. Unless the City has indicated otherwise for a specific procurement solicitation, either party may terminate these Standard Procurement Terms and Conditions, with or without cause, upon thirty (30) calendar days' notice to the other. Upon termination by the vendor, the City shall be entitled to retain ownership of any and all goods and equipment purchased. Upon termination by the City, the vendor shall be entitled to receive any amounts due as a result of goods and equipment already delivered and/or services already rendered; however, the City shall maintain ownership and control of any goods and equipment purchased. Upon termination of services, whether connected or unconnected to goods and equipment, such services shall be rendered until the conclusion of the 30<sup>th</sup> calendar day as stated in the notice or until a contractual benchmark has been achieved, or as the parties may otherwise agree.

## Standard Procurement Terms and Conditions

### City of Franklin, Tennessee

---

16. Breach. Upon deliberate breach of these Standard Procurement Terms and Conditions, or of any contract, agreement or other document which these Standard Procurement Terms and Conditions may accompany, by either party, the non-breaching party shall be entitled to terminate these Standard Procurement Terms and Conditions without notice, with all of the remedies it would have in the event of termination under section 10 ("Severability") above, and may also have such other remedies as it may be entitled to in law or in equity.
  
17. Default. If Vendor fails to perform or comply with any provision of these Standard Procurement Terms and Conditions, or of any contract, agreement or other document which these Standard Procurement Terms and Conditions may accompany, then the City (i) may cancel the purchase award and/or the accompanying contract or agreement or purchase order, in whole or in part, without penalty or protest by Vendor; (ii) may consider such failure to perform or comply as a breach of contract; (iii) reserves the right to purchase its requirements from the vendor that submitted the next lowest and best responsive and responsible bid, or the vendor that submitted the next best proposal, if that vendor will still honor that bid or proposal, or to seek new bids or proposals, or to pursue one or more other options available to the City in compliance with its then current purchasing policy; and (iv) may hold the defaulting vendor liable for all damages provided by law, including cost of cover.
  
18. Entire Agreement. These Standard Procurement Terms and Conditions, including any contract, agreement or other document which these Standard Procurement Terms and Conditions may accompany, constitutes the entire agreement between the parties and supersedes any prior or contemporaneous communications, representations or agreements between the parties, whether oral or written, regarding the subject matter of these Standard Procurement Terms and Conditions. The terms and conditions of these Standard Procurement Terms and Conditions may not be changed except by an amendment expressly referencing these Standard Procurement Terms and Conditions by section number and signed by an authorized representative of each party.
  
19. Survival. These Standard Procurement Terms and Conditions shall survive the completion of or any termination of any contract, agreement or other document which these Standard Procurement Terms and Conditions may accompany.

# Affidavit of Non-Collusion

a form required of Bidders and Proposers on purchases of supplies, materials, equipment and services for the City of Franklin, Tennessee

State of ALABAMA )  
County of MORGAN ) SS

Affiant, RONALD WOODALL, deposes and makes oath that:  
(printed name of person signing Affidavit)

1. He or she is the VICE PRESIDENT of  
(Owner or Authorized Partner, Officer, Representative or Agent of Owner)  
NORTH AMERICA FIRE EQUIPMENT CO., INC. (NAFECO),  
(legal name of entity submitting bid or proposal)

the Bidder or Proposer who has submitted the attached bid or proposal;

- 2. The Bidder or Proposer is fully informed respecting the preparation and content of the attached bid or proposal and of all pertinent circumstances respecting such bid or proposal;
- 3. Such bid or proposal is genuine and is not a collusive or sham bid or proposal;
- 4. Neither the said Bidder or Proposer nor any of its officers, partners, owners, agents, representatives, employees, or parties in interest, including this Affiant, has in any way colluded, conspired, connived or agreed, directly or indirectly, with any official or agent of the City of Franklin or with any other firm, person, or potential or actual bidder or proposer to submit a collusive or sham bid or proposal in connection with the contract for which the attached bid or proposal has been submitted, or to refrain from bidding or proposing indirectly, or sought by agreement, or collusion, or communication, or conference with any other firm, person, or potential or actual bidder or proposer to fix the price or prices or cost element of the bid, quoted or proposed price or the bid, quoted or proposed price of any other potential or actual bidder or proposer, or to secure through any collusion, conspiracy, connivance, or unlawful agreement any advantage against the City of Franklin or any person interested in the proposed contract;
- 5. The price or prices quoted in the attached bid or proposal are fair and proper and are not tainted by a collusion, conspiracy, connivance, or unlawful agreement on the part of the Bidder or Proposer or any of its agents, representatives, owners, employees, or parties in interest, including this Affiant; and
- 6. He or she understands that Article VIII, Section 16, of the City Charter of Franklin, and T.C.A. §6-54-107, prohibit any member of the Board of Mayor and Aldermen, or officer elected by said Board, from being interested in any contract, or work of any kind whatever, under its control and direction, and any contract in which any such person shall have an interest shall be void and unenforceable, subjecting any funds received by contractor to be returned in full to the City, in addition to any other penalties provided by law.

*Ronald Woodall*

(signature of Affiant)

VICE PRESIDENT

(title of Affiant)

Sworn and subscribed to before me this 2nd day of DECEMBER, 2014

*Angela Diane Chandler*  
(Notary Public)

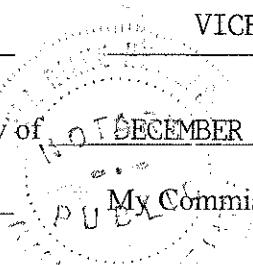

My Commission Expires: 7/15/18

(Submitted in response to City of Franklin Purchasing Office Solicitation No. 2015\_017)



**NAFECO**

Fire

Law Enforcement

EMS

Industrial

**CITY OF FRANKLIN, TN  
SOLICITATION NO. 2015-017**

**REFERENCES**

NASHVILLE FIRE LOGISTICS  
CAPTAIN RANDY CANE  
POST OFFICE BOX 196300  
NASHVILLE, TN 37219-6300  
615-862-5480  
Purchases PPE, Fire Equipment, etc. on an on-going basis

MURFREESBORO FIRE DEPARTMENT  
CHIEF ALLAN SWADER  
POST OFFICE BOX 1139  
MURFREESBORO, TN 37133  
615-893-1422  
Purchases PPE, Fire Equipment, etc. on an on-going basis

LEWISBURG FIRE DEPARTMENT  
CHIEF LARRY WILLIAMS  
118 WATER STREET  
LEWISBURG, TN 37091  
931-359-4214  
Purchases PPE, Fire Equipment, etc. on an on-going basis

*"Working to make our customers and our community better by providing solutions with the safest and highest quality equipment and services."*

**Corporate Office:** 1515 W Moulton St • Decatur, AL 35601  
**Office:** (800) 628.6233 • **Fax:** (256) 355.0852 • [www.nafeco.com](http://www.nafeco.com)



# Assault™ Nozzles

AKRON BRASS COMPANY | PH. 800.228.1161 (330.264.5670) | FAX 800.531.7335 (330.264.2944) | www.akronbrass.com

## 1 1/2" Electrical Assault Nozzles

- Designed to be used on class "C" hazards
- No straight stream capabilities (min. 30° fog)
- 100 psi (7 bar) operation pressure
- SPECIFY FLOW, 95 or 125 gpm (3600 or 475 lpm)
- 95 and 125 gpm only

**4815E** 1 1/2" Electrical Assault Nozzle with Spinning Teeth

**4820E** 1 1/2" Electrical Assault Nozzle with Pistol Grip and Spinning Teeth

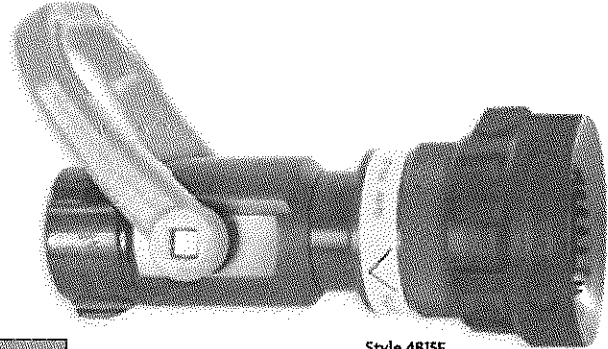

Style 4815E

| Style | Swivel Inlet   | Length          | Weight (lb. (kg)) | Flow Range       |                  |
|-------|----------------|-----------------|-------------------|------------------|------------------|
|       |                |                 |                   | GPM              | LPM              |
| 4815E | 1 1/2" (38 mm) | 8 3/4" (213 mm) | 3 1/2 (1.6 kg)    | 95 or 125 only * | 360 or 475 only* |
| 4820E | 1 1/2" (38 mm) | 8 3/4" (213 mm) | 3 3/4 (1.7 kg)    | 95 or 125 only * | 360 or 475 only* |

\* Must specify

## Mid-Range Assault Nozzles

- Quick change pattern adjustment
- SPECIFY PRESSURE AND FLOW, see chart below
- Compatible with Quick-Attack Foam Tube Style 777, See page 35
- Optional 2.5" inlet available upon request

**4862** Mid-Range Assault Nozzle

**4863** Mid-Range Assault Nozzle with Pistol Grip

**4864** Mid-Range Assault Breakapart Nozzle  
• Combination of Style 4867 tip with twist shutoff + Style 2129 shutoff

**4865** Mid-Range Assault Breakapart Nozzle with Pistol Grip  
• Combination of Style 4867 tip with twist shutoff + Style 2127 shutoff

**4866** Mid-Range Assault Tip

**4867** Mid-Range Assault Tip with Twist Shutoff



Style 4863

| Style | Swivel Inlet*  | Length           | Weight (lb. (kg)) |
|-------|----------------|------------------|-------------------|
| 4862  | 1 1/2" (38 mm) | 8 3/4" (222 mm)  | 4 (1.8 kg)        |
| 4863  | 1 1/2" (38 mm) | 9" (222 mm)      | 4 1/4 (1.9 kg)    |
| 4864  | 1 1/2" (38 mm) | 10 1/4" (276 mm) | 4 1/4 (1.9 kg)    |
| 4865  | 1 1/2" (38 mm) | 10 1/4" (276 mm) | 4 3/4 (2.1 kg)    |
| 4866  | 1 1/2" (38 mm) | 6 1/2" (165 mm)  | 2 3/4 (1.2 kg)    |
| 4867  | 1 1/2" (38 mm) | 6 1/2" (165 mm)  | 2 3/4 (1.2 kg)    |

\* Optional 2.5" inlet available upon request

| NOZZLE PSI | Pressure & Flow For Mid-Range Assault Nozzles |          |           |          |          |           |            |          |           |           |
|------------|---|----------|-----------|----------|----------|-----------|------------|----------|-----------|-----------|
|            | 150 @ 50                                      | 150 @ 75 | 150 @ 100 | 175 @ 50 | 175 @ 75 | 175 @ 100 | 200 @ 50 * | 200 @ 75 | 200 @ 100 | 225 @ 100 |
|            | Actual GPM                                    |          |           |          |          |           |            |          |           |           |
| 50         | 150   | 122      | 106       | 175      | 143      | 124       | 200        | 163      | 141       | 159       |
| 75         | 184   | 150      | 130       | 214      | 175      | 152       | 245        | 200      | 173       | 195       |
| 100        | 212   | 173      | 150       | 247      | 202      | 175       | 283        | 231      | 200       | 225       |

| NOZZLE BAR | Pressure & Flow For Mid-Range Assault Nozzles |         |         |         |         |         |         |         |         |         |
|------------|---|---------|---------|---------|---------|---------|---------|---------|---------|---------|
|            | 550 @ 3                                       | 550 @ 5 | 550 @ 7 | 660 @ 3 | 660 @ 5 | 660 @ 7 | 750 @ 3 | 750 @ 5 | 750 @ 7 | 850 @ 7 |
|            | Actual LPM                                    |         |         |         |         |         |         |         |         |         |
| 3          | 550   | 462     | 401     | 660     | 541     | 469     | 750     | 617     | 534     | 602     |
| 5          | 696   | 550     | 492     | 810     | 660     | 575     | 927     | 750     | 655     | 738     |
| 7          | 802   | 738     | 550     | 435     | 765     | 660     | 1071    | 874     | 750     | 852     |

\* No baffle kits available. Factory set only. Not available on 2.5" (65mm) inlets.

# Shutoffs & Shutoffs With Tips



Nozzles

## Saber™ Shutoffs With Integral Tip

Lightweight ball shutoff with an integral straight bore tip.



Style 2431

| Style | Pistol Grip | Finish   | Length          | Weight (lb./kg) | Orifice  | Threads        |                | Shutoff Waterway Size |
|-------|-------------|----------|-----------------|-----------------|--|----------------|----------------|-----------------------|
|       |             |          |                 |                 |  | Inlet          | Outlet         |                       |
| 2428  | -           | Pyrolite | 6" (150 mm)     | 1 5/8 (74 kg)   | 3/8", 1/2" (10, 13 mm)                                 | 1" (25 mm)     | 1" (25 mm)     | 1" (25 mm)            |
| 2429  | YES         | Pyrolite | 6" (150 mm)     | 2 3/8 (1.1 kg)  | 3/8", 1/2" (10, 13 mm)                                 | 1" (25 mm)     | 1" (25 mm)     | 1" (25 mm)            |
| 2430  | -           | Pyrolite | 6 7/8" (175 mm) | 2 1/4 (1.0 kg)  | 3/4", 7/8", 1 1/8", 1 1/4" (19, 22, 24, 25, 29, 32 mm) | 1 1/2" (38 mm) | 1 1/2" (38 mm) | 1 3/8" (29 mm)        |
| 2431  | YES         | Pyrolite | 6 7/8" (175 mm) | 3 (1.4 kg)      | 3/4", 7/8", 1 1/8", 1 1/4" (19, 22, 24, 25, 29, 32 mm) | 1 1/2" (38 mm) | 1 1/2" (38 mm) | 1 3/8" (29 mm)        |
| 2432  | -           | Pyrolite | 7 3/8" (187 mm) | 3 (1.4 kg)      | 3/4", 7/8", 1 1/8", 1 1/4" (19, 22, 24, 25, 29, 32 mm) | 2 1/2" (65 mm) | 1 1/2" (38 mm) | 1 3/8" (29 mm)        |
| 2433  | YES         | Pyrolite | 7 3/8" (187 mm) | 3 1/2 (1.6 kg)  | 3/4", 7/8", 1 1/8", 1 1/4" (19, 22, 24, 25, 29, 32 mm) | 2 1/2" (65 mm) | 1 1/2" (38 mm) | 1 3/8" (29 mm)        |

## Pyrolite Shutoffs

- Tough, lightweight ball shutoffs with a full-time swivel base ensures the handle can be positioned for easy operation.

| Standard Waterway Size 1" (For Flows Less Than 100 GPM) |             |          |                 |                 |                |                |                       |
|---|-------------|----------|-----------------|-----------------|----------------|----------------|-----------------------|
| Style   | Pistol Grip | Finish   | Length          | Weight (lb./kg) | Threads        |                | Shutoff Waterway Size |
|   |             |          |                 |                 | Inlet Female   | Outlet Male    |                       |
| 2101  | -           | Pyrolite | 4 1/4" (108 mm) | 1 1/4 (.6 kg)   | 1" (25 mm)     | 1" (25 mm)     | 1" (25 mm)            |
| 2102  | YES         | Pyrolite | 4 1/4" (108 mm) | 2 (.9 kg)       | 1" (25 mm)     | 1" (25 mm)     | 1" (25 mm)            |
| 2108  | YES         | Pyrolite | 4 1/2" (114 mm) | 1 5/8 (.7 kg)   | 1" (25 mm)     | 1 1/2" (38 mm) | 1" (25 mm)            |
| 2115  | -           | Pyrolite | 4 1/2" (114 mm) | 1 1/2 (.7 kg)   | 1 1/2" (38 mm) | 1 1/2" (38 mm) | 1" (25 mm)            |
| 2116  | YES         | Pyrolite | 4 1/2" (114 mm) | 1 7/8 (.9 kg)   | 1 1/2" (38 mm) | 1 1/2" (38 mm) | 1" (25 mm)            |

| Standard Waterway Size 1 1/2" (For Flows More Than 100 GPM) |             |          |                 |                 |                |                |                       |
|---|-------------|----------|-----------------|-----------------|----------------|----------------|-----------------------|
| Style   | Pistol Grip | Finish   | Length          | Weight (lb./kg) | Threads        |                | Shutoff Waterway Size |
|   |             |          |                 |                 | Inlet Female   | Outlet Male    |                       |
| 2125  | -           | Pyrolite | 6" (152 mm)     | 2 1/8 (1.2 kg)  | 2 1/2" (65 mm) | 1 1/2" (38 mm) | 1 3/8" (35 mm)        |
| 2126  | YES         | Pyrolite | 6" (152 mm)     | 2 7/8 (1.3 kg)  | 2 1/2" (65 mm) | 1 1/2" (38 mm) | 1 3/8" (35 mm)        |
| 2127  | YES         | Pyrolite | 4 7/8" (124 mm) | 2 1/8 (1.0 kg)  | 1 1/2" (38 mm) | 1 1/2" (38 mm) | 1 3/8" (35 mm)        |
| 2129  | -           | Pyrolite | 4 7/8" (124 mm) | 1 3/4 (.8 kg)   | 1 1/2" (38 mm) | 1 1/2" (38 mm) | 1 3/8" (35 mm)        |
| 2130  | -           | Pyrolite | 6 3/8" (162 mm) | 4 1/4 (1.9 kg)  | 2 1/2" (65 mm) | 2 1/2" (65 mm) | 2" (51 mm)            |

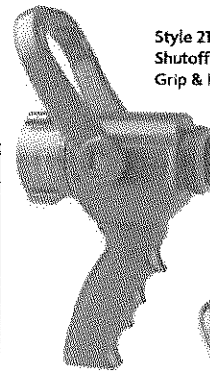

Style 2127 Shutoff with Pistol Grip & Handle

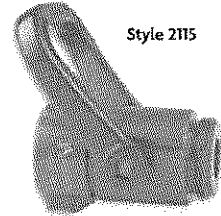

Style 2115

## Pyrolite® Shutoffs With Dual Stacked Tips

Lightweight ball shutoff with Style 439 tips for use where a fog nozzle is not required. Base tip has a female thread on the outlet for added protection and durability.

| Style | Pistol Grip | Finish   | Length           | Weight (lb./kg) | Inlet          | Orifices                   | Combination |     | Shutoff Waterway Size |
|-------|-------------|----------|------------------|-----------------|----------------|----------------------------|-------------|-----|-----------------------|
|       |             |          |                  |                 |                |                            | Shutoff     | Tip |                       |
| 1440  | -           | Pyrolite | 10 3/8" (264 mm) | 2 1/2 (1.3 kg)  | 1 1/2" (38 mm) | 5/8" x 1/2" (24 x 13 mm)   | 2129        | 439 | 1 3/8" (35 mm)        |
| 1441  | YES         | Pyrolite | 10 3/8" (264 mm) | 2 7/8 (1.3 kg)  | 1 1/2" (38 mm) | 5/8" x 1/2" (24 x 13 mm)   | 2127        | 439 | 1 3/8" (35 mm)        |
| 1442  | -           | Pyrolite | 11 1/2" (292 mm) | 3 3/8 (1.5 kg)  | 2 1/2" (65 mm) | 1 1/8" x 1/2" (29 x 13 mm) | 2125        | 439 | 1 3/8" (35 mm)        |
| 1443  | YES         | Pyrolite | 11 1/2" (292 mm) | 4 5/8 (2.1 kg)  | 2 1/2" (65 mm) | 1 1/8" x 1/2" (29 x 13 mm) | 2126        | 439 | 1 3/8" (35 mm)        |



Style 1440

## Mini Tips

Pyrolite shutoff with pistol grip and straight tip for high volume low pressure operation. Nearly 400 gpm at 50 psi.

| Style | Pistol Grip | Finish   | Length           | Weight (lb./kg) | Orifice        | Threads        |                | Combination |      | Shutoff Waterway Size |
|-------|-------------|----------|------------------|-----------------|----------------|----------------|----------------|-------------|------|-----------------------|
|       |             |          |                  |                 |                | Inlet          | Tip            | Shutoff     | Tip  |                       |
| 1445  | YES         | Pyrolite | 10" (254 mm)     | 3 3/8 (1.5 kg)  | 1 1/8" (35 mm) | 1 1/2" (38 mm) | 1 1/2" (38 mm) | 2127        | 1499 | 1 3/8" (35 mm)        |
| 1446  | YES         | Pyrolite | 10 5/8" (270 mm) | 4 5/8 (2.1 kg)  | 1 1/8" (35 mm) | 2 1/2" (65 mm) | 1 1/2" (38 mm) | 2126        | 1499 | 1 3/8" (35 mm)        |

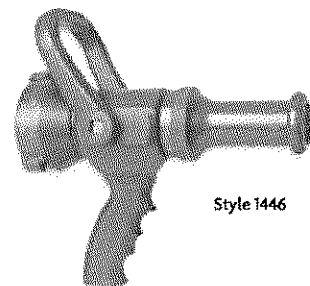

Style 1446

# Assault™ Nozzles



Nozzles

## High-Range Assault Nozzles

- Quick change pattern adjustment
- SPECIFY PRESSURE AND FLOW, see chart below



- 4822** 1 1/2" High-Range Assault Nozzle with Spinning Teeth
- 4722** 1 1/2" High-Range Assault Nozzle Less Teeth
- 4823\*** 1 1/2" High-Range Assault Nozzle with Pistol Grip and Spinning Teeth\*
- 4824** 1 1/2" High-Range Assault Tip with Spinning Teeth
- 4724** 1 1/2" High-Range Assault Tip Less Teeth
- 4825** 2 1/2" High-Range Assault Nozzle with Spinning Teeth
- 4826\*** 2 1/2" High-Range Assault Nozzle with Pistol Grip and Spinning Teeth\*
- 4726** 2 1/2" High-Range Assault Nozzle with Pistol Grip Less Teeth
- 4827** 1 1/2" High-Range Assault Tip with Twist Shutoff and Spinning Teeth
- 4830** 2 1/2" High-Range Assault Tip with Axial Playpipe
  - Combination of Style 4827 tip with twist shutoff + Style 2390 playpipe
- 4834** 1 1/2" High-Range Assault Breakapart Nozzle with Pistol Grip
  - Combination of Style 4827 tip with twist shutoff + Style 2127 shutoff
- 4835** 1 1/2" High-Range Assault Breakapart Nozzle
  - Combination Style 4827 tip with twist shutoff + Style 2129 shutoff
- 4836** 2 1/2" High-Range Assault Breakapart Nozzle with Pistol Grip
  - Combination of Style 4827 tip with twist shutoff + Style 2126 shutoff
- 4837\*** 2 1/2" High-Range Assault Tip with Twist Shutoff and Spinning Teeth\*
- 4838** 2 1/2" High-Range Assault Breakapart Nozzle
  - Combination of Style 4827 tip with twist shutoff + Style 2125 shutoff

| Style | Orifice diam.  | Length            | Weight (kg)     |
|-------|----------------|-------------------|-----------------|
| 4722  | 1 1/2" (38 mm) | 12 3/16" (309 mm) | 6 1/2 (7.5 kg)  |
| 4724  | 1 1/2" (38 mm) | 9 1/2" (231 mm)   | 5 1/8 (3.2 kg)  |
| 4726  | 2 1/2" (65 mm) | 12 3/16" (309 mm) | 7 1/8 (3.2 kg)  |
| 4822  | 1 1/2" (38 mm) | 11 1/2" (292 mm)  | 6 1/2 (7.5 kg)  |
| 4823* | 1 1/2" (38 mm) | 11 1/2" (292 mm)  | 7 1/4 (3.3 kg)  |
| 4824  | 1 1/2" (38 mm) | 8 1/4" (210 mm)   | 5 1/4 (2.4 kg)  |
| 4825  | 2 1/2" (65 mm) | 12 1/8" (206 mm)  | 7 1/8 (3.2 kg)  |
| 4826* | 2 1/2" (65 mm) | 12 1/8" (206 mm)  | 7 3/8 (3.5 kg)  |
| 4827  | 1 1/2" (38 mm) | 8 3/4" (222 mm)   | 5 1/4 (2.7 kg)  |
| 4830  | 2 1/2" (65 mm) | 16 3/4" (425 mm)  | 11 3/8 (5.2 kg) |
| 4834  | 1 1/2" (38 mm) | 13 1/2" (343 mm)  | 8 (3.6 kg)      |
| 4835  | 1 1/2" (38 mm) | 13 1/8" (333 mm)  | 7 3/8 (3.5 kg)  |
| 4836  | 2 1/2" (65 mm) | 14" (356 mm)      | 8 3/4 (4.0 kg)  |
| 4837* | 2 1/2" (65 mm) | 9 1/2" (241 mm)   | 6 1/2 (2.9 kg)  |
| 4838  | 2 1/2" (65 mm) | 13 3/8" (346 mm)  | 8 1/2 (3.9 kg)  |

\* FM Approved Styles 4823, 4826 & 4837

2 1/2" Assaults meet Insurance Services Office (ISO) requirements.

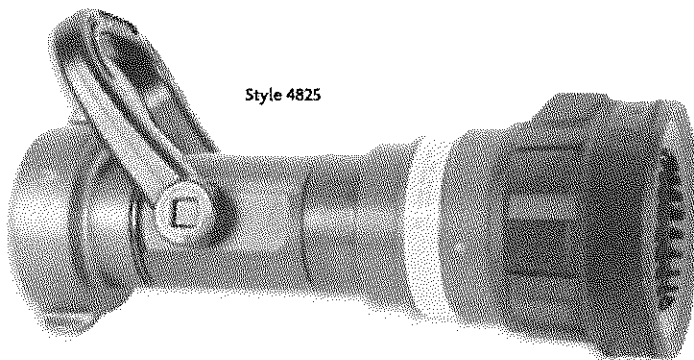

Style 4825

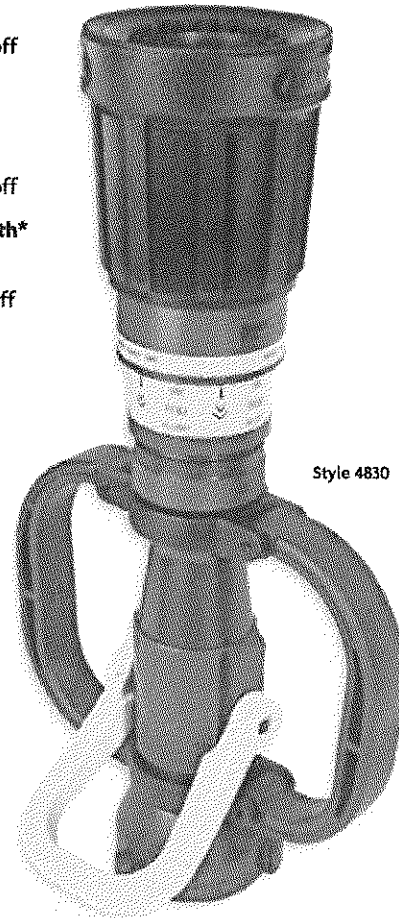

Style 4830

### Pressure & Flow Options For High-Range Assault Nozzles

| NOZZLE PSI | 200 @ 75   | 200 @ 100 | 250 @ 50 | 250 @ 75 | 250 @ 100 | 300 @ 75 | 300 @ 100 | 350 @ 100 |
|------------|------------|-----------|----------|----------|-----------|----------|-----------|-----------|
|            | Actual GPM |           |          |          |           |          |           |           |
| 50         | 163        | 141       | 250      | 204      | 177       | 245      | 212       | 247       |
| 75         | 200        | 173       | 306      | 250      | 217       | 300      | 260       | 303       |
| 100        | 231        | 200       | 354      | 289      | 250       | 346      | 300       | 350       |

### Pressure & Flow Options For High-Range Assault Nozzles

| NOZZLE Bar | 750 @ 5    | 750 @ 7 | 950 @ 3 | 950 @ 5 | 950 @ 7 | 1140 @ 5 | 1140 @ 7 | 1325 @ 7 |
|------------|------------|---------|---------|---------|---------|----------|----------|----------|
|            | Actual LPM |         |         |         |         |          |          |          |
| 3          | 617        | 534     | 950     | 772     | 670     | 927      | 802      | 935      |
| 5          | 750        | 655     | 1158    | 950     | 821     | 1140     | 984      | 1147     |
| 7          | 874        | 750     | 1340    | 1094    | 950     | 1310     | 1140     | 1325     |



# Straight Tips

AKRON BRASS COMPANY | PH. 800.228.1161 (330.264.5678) | FAX 800.511.7335 (330.264.2944) | www.akronbrass.com

## Straight Tips

- 416**    **1 1/2" Thread Tip**
  - Now available in Pyrolite®
  - Intergrated Thread Protector
  - Protective rubber bumper
  - 1 1/8" standard orifice (see chart below for orifice options)
- 417**    **1 1/2" Plain Tip**
  - Protective rubber bumper
  - 1 1/8" standard orifice (see chart below for orifice options)
- 438**    **1 1/2" Plain Tip**
  - Protective rubber bumper
  - 1/2" standard orifice (see chart below for orifice options)
- 489**    **Plain Deluge Tip**
  - 2 1/2" Inlet
    - 1 1/2" standard orifice (see chart below for orifice options)
  - 3" Inlet
    - 2" standard orifice (see chart below for orifice options)
- 1410**    **1" Plain Tip**
  - 3/8" standard orifice (5/8" optional orifice)
- 1417**    **1 1/2" Plain Tip**
  - 7/8" standard orifice (see chart below for orifice options)
- 1430**    **1 1/2" Threaded Saber™ Tip**
  - Can be used with a fog tip, foam nozzle or applicator
  - Designed for use in high rise packs
  - 7/8" standard orifice (15/16" optional orifice)
- 1499**    **1 1/2" Plain Tip**
  - 1 3/8" standard orifice (see chart below for orifice options)
- 2489**    **3 1/2" MasterStream Tip**
  - 2" Orifice
- 3489**    **3 1/2" Shaper Tip**
  - Combination stream shaper & tip designed for use with Akron Brass StreamMaster™ monitors.
  - 2 1/2" standard orifice (2 3/4" optional orifice)

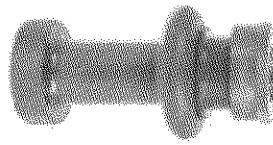

Style 416

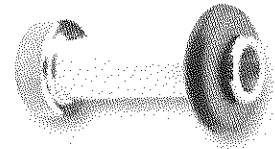

Style 417

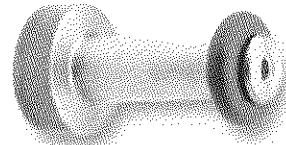

Style 438



Style 489

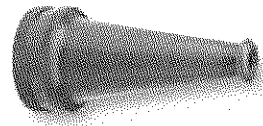

Style 1410

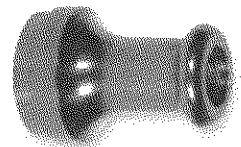

Style 1417

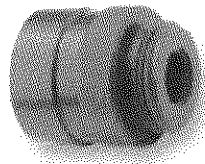

Style 1430

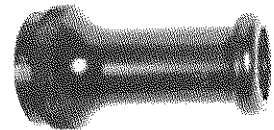

Style 1499

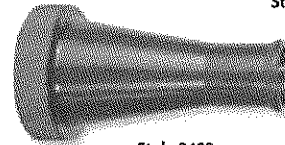

Style 2489



Style 3489

| Style | Length           | Weight (lb./kg)                          | Orifice        |  | Threads                         | Finish             |
|-------|------------------|--|----------------|--|---------------------------------|--------------------|
|       |                  |  | Standard       | Optional   |                                 |                    |
| 416   | 6" (152 mm)      | 2 3/4 (1.2 kg)                           | 1 1/8" (29 mm) | 3/4", 7/8", 1", 1 1/4"<br>(19, 22, 25, 32 mm)  | 1 1/2" X 1 1/2"<br>(38 x 38 mm) | Brass or Pyrolite  |
| 417   | 6" (152 mm)      | 2 (9 kg)                                 | 1 1/8" (29 mm) | 3/4", 7/8", 1", 1 1/4"<br>(19, 22, 25, 32 mm)  | 1 1/2" (38 mm)                  | Brass              |
| 438   | 4 1/4" (111 mm)  | 1 1/4 (.6 kg)                            | 1/2" (13 mm)   | 3/8", 5/8" (9.5, 16 mm)  | 1 1/2" (38 mm)                  | Brass              |
| 489   | 9" (229 mm)      | 3-brass (1.4 kg)<br>1-alum. (.5 kg)      | 1 1/2" (38 mm) | 7/8", 1 1/4", 1 3/4", 1 3/2", 2", 2 1/4"<br>(22, 32, 35, 44, 50, 57 mm)                    | 2 1/2" (65 mm)                  | Brass or Aluminium |
| 489   | 10 1/2" (267 mm) | 5-brass (2.3 kg)<br>1 3/4 -alum. (.8 kg) | 2" (50 mm)     | 1 3/4", 2 1/4", 2 1/2"<br>(44, 57, 65 mm)  | 3" NPSH (75 mm)                 | Brass or Aluminium |
| 1410  | 4 1/2" (114 mm)  | 3/8 (.2 kg)                              | 3/8" (10 mm)   | 5/8" (16 mm)   | 1" (25 mm)                      | Pyrolite           |
| 1417  | 3 3/4" (95 mm)   | 3/4 (.3 kg)                              | 7/8" (22 mm)   | 3/8", 1/2", 5/8", 3/4", 5/8", 1", 1 1/8", 1 1/4" ◦<br>(9.5, 13, 16, 19, 24, 25, 29, 32 mm) | 1 1/2" (38 mm)                  | Pyrolite           |
| 1430  | 2 7/8" (73 mm)   | 3/4 (.3 kg)                              | 7/8" (22 mm)   | 15/16" (25 mm)   | 1 1/2" X 1 1/2"<br>(38 x 38 mm) | Pyrolite           |
| 2489  | 9" (229 mm)      | 2 3/4 (1.2 kg)                           | 2" (52 mm)     | 3" (75 mm)   | 3 1/2" NH (89 mm)               | Pyrolite           |
| 1499* | 5" (127 mm)      | 3/4 (.3 kg)                              | 1 3/8" (35 mm) | 7/8", 15/16", 1", 1 1/8", 1 1/4"<br>(22, 24, 25, 29, 32 mm)                                | 1 1/2" NH (38 mm)               | Pyrolite           |
| 3489  | 19" (483 mm)     | 6 (2.7 kg)                               | 2 1/2" (65 mm) | 2 3/4" (70 mm)   | 3 1/2" NH (89 mm)               | Pyrolite           |

\* Available with set screw for permanent attachment - Must Specify

\*\* 2 1/4" designed for testing purposes only

◦ 3/8" tip NH thread only





# Wyes & Water Thief

AKRON BRASS COMPANY | PH. 800.228.1161 (330.264.5678) | FAX 800.531.7335 (330.264.2944) | www.akronbrass.com

## Gated Wyes

- 1480**    **1 1/2" Wye**
- 1482**    **Hydrant Wye**
  - Self-locking Tork-Lok® handles for positive handle positioning
- 1581**    **Leader Line Wye**
  - Self-locking Tork-Lok® handles for positive handle positioning
- 1582**    **Hydrant Wye**
  - Self-locking Tork-Lok handles for positive handle positioning
- 2580**    **1 1/2" Wye**
  - High strength polymer handles
- 2581**    **Leader Line Wye**
  - High strength polymer handles
- 2582**    **3-Way Hydrant Wye**
  - Self-locking Tork-Lok handles for positive handle positioning
- 2681**    **Leader Line Wye**
  - Designed for heavy-duty use in severe environments.
  - High strength polymer handles & balls standard
  - Optional metal handles & balls

| Style | Material  | Length           | Width            | Weight (lb./kg)    | Inlet   | Outlet                                   |
|-------|-----------|------------------|------------------|--------------------|---|--|
| 1480  | Brass     | 5 1/8" (130 mm)  | 6 5/8" (168 mm)  | 11 1/4 (5.1 kg)    | 1 1/2" F (38 mm)  | (2) 1 1/2" M (38 mm)                     |
| 1482  | Brass     | 8 1/2" (209 mm)  | 12" (305 mm)     | * 31 1/4 (14.2 kg) | 2 1/2"-6" F (65-150 mm)                                   | (2) 2 1/2" M (65 mm)                     |
| 1581  | Pyrolite® | 5 3/4" (146 mm)  | 6 3/4" (171 mm)  | 5 1/2 (2.5 kg)     | 2 1/2" F (65 mm)  | (2) 1 1/2" M (38 mm)                     |
| 1582  | Pyrolite  | 9 1/2" (241 mm)  | 11" (279 mm)     | * 16 3/4 (7.6 kg)  | 2 1/2"-6" F (65-150 mm)<br>4" or 5" Storz (100 or 125 mm) | (2) 2 1/2" M (65 mm)                     |
| 2580  | Pyrolite  | 5 1/2" (140 mm)  | 7" (178 mm)      | 3 (1.4 kg)         | 1 1/2" F (38 mm)  | (2) 1 1/2" M (38 mm) or (2) 1" M (25 mm) |
| 2581  | Pyrolite  | 5 1/2" (140 mm)  | 7" (178 mm)      | 3 (1.4 kg)         | 2 1/2" F (65 mm)  | (2) 1 1/2" M (38 mm)                     |
| 2582  | Pyrolite  | 11 1/4" (298 mm) | 15 1/2" (394 mm) | * 24 1/2 (11 kg)   | 2 1/2"-6" F (65-150 mm)<br>4" or 5" Storz (100 or 125 mm) | (3) 2 1/2" M (65 mm)                     |
| 2681  | Brass     | 7 1/2" (19 cm)   | 5 1/2" (13.3 cm) | 10 1/2 (3.4 kg)    | 2 1/2" F (65 mm)  | (2) 1 1/2" M (38 mm)                     |

\* Weight with 4 1/2" (11.4 cm) inlet



Style 1480

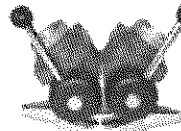

Style 1482



Style 1581

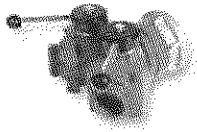

Style 1582



Style 2580



Style 2581



Style 2582



Style 2681

## Plain Wyes

| Style | Material | Length          | Width       | Weight (lb./kg) | Inlet                     | Outlet                               |
|-------|----------|-----------------|-------------|-----------------|---------------------------|--------------------------------------|
| 260   | Brass    | 6 3/4" (171 mm) | 8" (203 mm) | 7* (3.2 kg)     | 2 1/2"-6" F (65-150 mm)   | (2) 1 1/2" or 2 1/2" M (38 or 65 mm) |
| 1260  | Pyrolite | 9 1/2" (232 mm) | 8" (203 mm) | 6 3/4* (3.1 kg) | 2 1/2"-6" F** (65-150 mm) | 2" - 2 1/2" M** (50 - 65 mm)         |

\* Weight with 4 1/2" (114 mm) inlet

\*\* Storz optional



Style 260



Style 1260

## Water Thief

For extending 1 1/2" or 2 1/2" lines without interfering with the operation of other lines. Includes Self-locking Tork-Lok handles for more positive handle positioning.

| Style | Material | Length          | Width            | Weight (lb./kg) | Inlet            | Outlet                                   |
|-------|----------|-----------------|------------------|-----------------|------------------|--|
| 1573  | Pyrolite | 9 3/4" (238 mm) | 10 1/2" (267 mm) | 12 (5.4 kg)     | 2 1/2" F (65 mm) | (2) 1 1/2" M & (1) 2 1/2" M (38 & 65 mm) |
| 273   | Brass    | 9 3/4" (238 mm) | 10 1/2" (267 mm) | 27 (12.5 kg)    | 2 1/2" F (65 mm) | (2) 1 1/2" M & (1) 2 1/2" M (38 & 65 mm) |

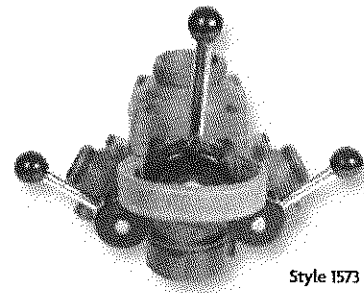

Style 1573

[Customer Support](#)[Contact Us](#)[Find a Product Expert](#)[Find a Distributor](#)[Request Product Demonstration](#)[Repairs](#)[Returns \(RMA\)](#)[Warranty](#)[Order Forms](#)[Resource Center](#)

## Warranty Information

### Akron Brass



**WARRANTY AND DISCLAIMER:** We warrant Akron Brass products for a period of five (5) years\* after purchase against defects in materials or workmanship. Akron Brass will repair or replace product which fails to satisfy this warranty. Repair or replacement shall be at the discretion of Akron Brass. Products must be promptly returned to Akron Brass for warranty service. We will not be responsible for: wear and tear; any improper installation, use, maintenance or storage; negligence of the owner or user; repair or modification after delivery; damage; failure to follow our instructions or recommendations; or anything else beyond our control. **WE MAKE NO WARRANTIES, EXPRESS OR IMPLIED, OTHER THAN THOSE INCLUDED IN THIS WARRANTY STATEMENT, AND WE DISCLAIM ANY IMPLIED WARRANTY OF MERCHANTABILITY OR FITNESS FOR ANY PARTICULAR PURPOSE.** Further, we will not be responsible for any consequential, incidental or indirect damages (including, but not limited to, any loss of profits) from any cause whatsoever. No person has authority to change this warranty.



\*Turbojet, Assault, SaberJet, Heavy Duty Swing Out Valves and Black Max Piston Intake Valves all carry an extended 10 year warranty. All Industrial electronic warranties are limited to 1 year.

[REQUEST PRODUCT DEMO](#)

Contact us for a hands-on demonstration.

[FIND A DISTRIBUTOR](#)

Learn where to buy.

[CUSTOM SOLUTIONS](#)

Contact an engineer for a solution customized to your needs.

[RESOURCE CENTER](#)

Get access to useful guides and reference material to help you get the most out of your Akron Brass products.

### Weldon, a division of Akron Brass:

The Supplier warrants that for a minimum period of twenty-four (24) months from the date of manufacture, goods sold hereunder will be free from defects in materials and workmanship. Supplier produces multiple goods, some having warranty periods beyond twenty-four (24) months; please call the Customer Service Department to obtain the exact warranty length for specific goods. All warranty periods commence from the date the goods were manufactured. The sole and exclusive remedy of the Buyer for a breach of the Supplier's warranty hereunder shall be the repair or replacement, at the Supplier's option, of any defective or non-conforming goods. This warranty shall apply only where the Buyer has returned the goods under a RGA, shipping costs prepaid by the Buyer, along with a detailed written notice of the alleged defects or deficiencies within ninety (90) days after such defect or nonconformity is discovered. This warranty does not extend to any goods that are considered by Supplier to be consumable or wear goods, or to goods that have been subjected to abuse, misuse, neglect or accident, or to any goods that has been repaired or altered by other than the Supplier. **THE WARRANTY SET FORTH IN THIS PARAGRAPH IS THE SOLE AND EXCLUSIVE WARRANTY AND IS IN LIEU OF ALL OTHER WARRANTIES, EXPRESS OR IMPLIED, INCLUDING ANY WARRANTIES OF MERCHANTABILITY, TITLE, OR FITNESS FOR A PARTICULAR PURPOSE. THE SUPPLIER SHALL UNDER NO CIRCUMSTANCES BE LIABLE TO THE BUYER OR TO ANY THIRD PARTY FOR ANY CONSEQUENTIAL, INCIDENTAL, INDIRECT, PUNITIVE, OR SPECIAL DAMAGES, IRRESPECTIVE OF WHETHER THE ALLEGED BASIS FOR LIABILITY IS FOUNDED ON WARRANTY, CONTRACT, TORT, STATUTE, REGULATION, EQUITABLE CONSIDERATION OR ANY OTHER THEORY.**

#### REPAIR CENTER

Get your product back in service.

[SUBMIT A REPAIR](#)

#### REQUEST OR DOWNLOAD PRODUCT CATALOG

Download or request print copy or CD

[REQUEST/VIEW CATALOG](#)

#### NEWSLETTER SIGN UP

Get updates, industry news and more by email.

Enter email address.

[SIGN UP](#)



# CERTIFICATE OF LIABILITY INSURANCE

NORTAMF-01

BROB

DATE (MM/DD/YYYY)

THIS CERTIFICATE IS ISSUED AS A MATTER OF INFORMATION ONLY AND CONFERS NO RIGHTS UPON THE CERTIFICATE HOLDER. THIS CERTIFICATE DOES NOT AFFIRMATIVELY OR NEGATIVELY AMEND, EXTEND OR ALTER THE COVERAGE AFFORDED BY THE POLICIES BELOW. THIS CERTIFICATE OF INSURANCE DOES NOT CONSTITUTE A CONTRACT BETWEEN THE ISSUING INSURER(S), AUTHORIZED REPRESENTATIVE OR PRODUCER, AND THE CERTIFICATE HOLDER.

**IMPORTANT:** If the certificate holder is an ADDITIONAL INSURED, the policy(ies) must be endorsed. If SUBROGATION IS WAIVED, subject to the terms and conditions of the policy, certain policies may require an endorsement. A statement on this certificate does not confer rights to the certificate holder in lieu of such endorsement(s).

|  |  |  |
|--|--|--|
| PRODUCER<br>Stovall Marks Insurance Inc.<br>2601 Danville Rd SW<br>Decatur, AL 35603                               | (256) 355-7951   | CONTACT NAME: <b>Barbara Broadfoot</b>   |
|  |  | PHONE (A/C, No, Ext): <b>(256) 355-7951</b> FAX (A/C, No): <b>(256) 350-2022</b> |
|  |  | E-MAIL ADDRESS: <b>bbroadfoot@stovallmarks.com</b>                               |
|  |  | INSURER(S) AFFORDING COVERAGE  |
| INSURED<br><b>North America Fire Equipment Co., inc.</b><br><b>1515 W. Moulton St.</b><br><b>Decatur, AL 35601</b> | INSURER A : <b>AIX Specialty Insurance Company</b> <b>12833</b>            |  |
|  | INSURER B : <b>Ohio Security Insurance Company</b> <b>24082</b>            |  |
|  | INSURER C : <b>Associated International Insurance Company</b> <b>27189</b> |  |
|  | INSURER D : <b>Aia SIWCF/Midwest Employers Casualty Co.</b> <b>23612</b>   |  |
|  | INSURER E : <b>Sentry Insurance Company</b> <b>24988</b>                   |  |
|  | INSURER F :  |  |

COVERAGES CERTIFICATE NUMBER: REVISION NUMBER:

THIS IS TO CERTIFY THAT THE POLICIES OF INSURANCE LISTED BELOW HAVE BEEN ISSUED TO THE INSURED NAMED ABOVE FOR THE POLICY PERIOD INDICATED. NOTWITHSTANDING ANY REQUIREMENT, TERM OR CONDITION OF ANY CONTRACT OR OTHER DOCUMENT WITH RESPECT TO WHICH THIS CERTIFICATE MAY BE ISSUED OR MAY PERTAIN, THE INSURANCE AFFORDED BY THE POLICIES DESCRIBED HEREIN IS SUBJECT TO ALL THE TERMS, EXCLUSIONS AND CONDITIONS OF SUCH POLICIES. LIMITS SHOWN MAY HAVE BEEN REDUCED BY PAID CLAIMS.

| INSR LTR | TYPE OF INSURANCE   | ADDL/SUBR INSD WVR | POLICY NUMBER         | POLICY EFF (MM/DD/YYYY) | POLICY EXP (MM/DD/YYYY) | LIMITS  |
|----------|---|--------------------|-----------------------|-------------------------|-------------------------|---|
| A        | <input checked="" type="checkbox"/> COMMERCIAL GENERAL LIABILITY<br><input type="checkbox"/> CLAIMS-MADE <input checked="" type="checkbox"/> OCCUR<br><br>GEN'L AGGREGATE LIMIT APPLIES PER:<br><input checked="" type="checkbox"/> POLICY <input type="checkbox"/> PRO-JECT <input type="checkbox"/> LOC<br>OTHER: |                    | LIA A179022           | 12/12/2013              | 12/12/2014              | EACH OCCURRENCE \$ 2,000,000<br>DAMAGE TO RENTED PREMISES (Ea occurrence) \$ 50,000<br>MED EXP (Any one person) \$ 1,000<br>PERSONAL & ADV INJURY \$ 2,000,000<br>GENERAL AGGREGATE \$ 4,000,000<br>PRODUCTS - COMP/OP AGG \$ 4,000,000 |
| B        | <input checked="" type="checkbox"/> AUTOMOBILE LIABILITY<br><input type="checkbox"/> ANY AUTO<br><input type="checkbox"/> ALL OWNED AUTOS <input type="checkbox"/> SCHEDULED AUTOS<br><input type="checkbox"/> HIRED AUTOS <input type="checkbox"/> NON-OWNED AUTOS   |                    | BAS54389438           | 3/10/2014               | 3/10/2015               | COMBINED SINGLE LIMIT (Ea accident) \$ 1,000,000<br>BODILY INJURY (Per person) \$<br>BODILY INJURY (Per accident) \$<br>PROPERTY DAMAGE (Per accident) \$   |
| C        | <input type="checkbox"/> UMBRELLA LIAB <input checked="" type="checkbox"/> OCCUR<br><input checked="" type="checkbox"/> EXCESS LIAB <input type="checkbox"/> CLAIMS-MADE<br>DED RETENTION \$  |                    | XOBW5031314           | 3/10/2014               | 3/10/2015               | EACH OCCURRENCE \$ 1,000,000<br>AGGREGATE \$ 1,000,000  |
| D        | <input type="checkbox"/> WORKERS COMPENSATION AND EMPLOYERS' LIABILITY<br><input type="checkbox"/> ANY PROPRIETOR/PARTNER/EXECUTIVE OFFICER/MEMBER EXCLUDED? (Mandatory in NH)<br>If yes, describe under DESCRIPTION OF OPERATIONS below  | Y/N<br>N N/A       | 1-3745114-PKAL-129001 | 1/1/2014                | 1/1/2015                | <input checked="" type="checkbox"/> PER STATUTE <input type="checkbox"/> OTH-ER<br>E.L. EACH ACCIDENT \$ 1,000,000<br>E.L. DISEASE - EA EMPLOYEE \$ 1,000,000<br>E.L. DISEASE - POLICY LIMIT \$ 1,000,000                               |
| E        | Workers Compensation  |                    | 90-53270-01 00 141    | 1/1/2014                | 1/1/2015                | Out of State 1/1/1,000,000  |

DESCRIPTION OF OPERATIONS / LOCATIONS / VEHICLES (ACORD 101, Additional Remarks Schedule, may be attached if more space is required)



|                    |   |
|--------------------|---|
| CERTIFICATE HOLDER | CANCELLATION  |
|                    | SHOULD ANY OF THE ABOVE DESCRIBED POLICIES BE CANCELLED BEFORE THE EXPIRATION DATE THEREOF, NOTICE WILL BE DELIVERED IN ACCORDANCE WITH THE POLICY PROVISIONS.<br><br>AUTHORIZED REPRESENTATIVE<br> |

© 1988-2014 ACORD CORPORATION. All rights reserved.